

CITY OF GRANGER
YAKIMA COUNTY WASHINGTON

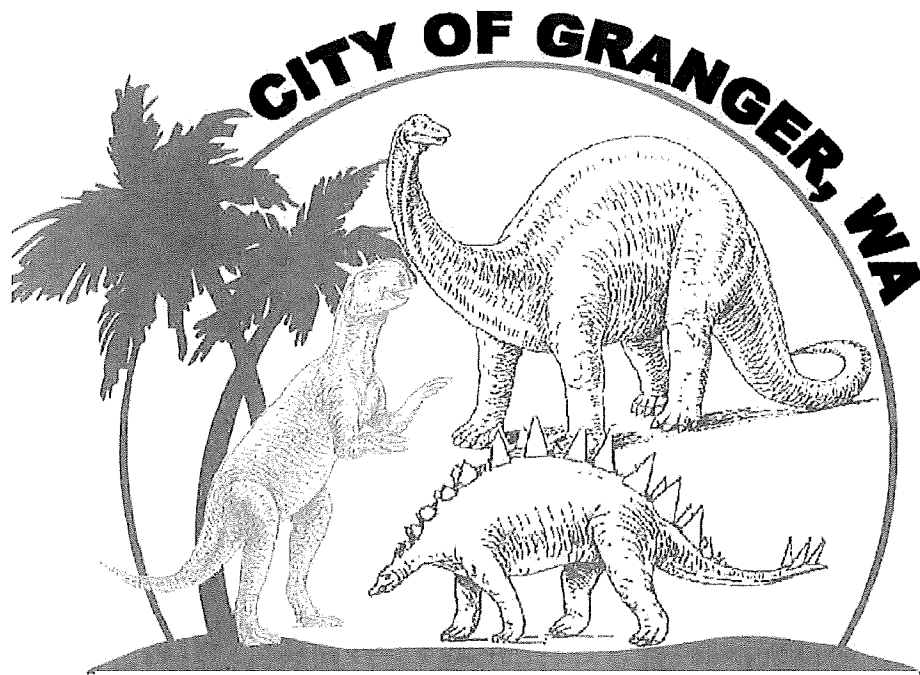

**DEVELOPER GUIDELINES
AND
PUBLIC WORKS DESIGN STANDARDS**

SEPTEMBER 2017



1045 Jordan Ave., Suite E • Richland, WA • 509.946.1581 • www.spinkeng.com

CHAPTER 1 – GENERAL

1. ENACTING AUTHORITY

These Design and Construction Standards are enacted by the City of Granger, in accordance with state law, to protect and preserve the public health, safety, and general welfare.

2. PURPOSE

The purpose of these Design and Construction Standards is to provide consistent requirements, standards, and specifications for the design and construction of public works infrastructure improvements by the City and by private developers.

3. STATE ENVIRONMENT POLICY ACT (SEPA)

These Design and Construction Standards will not affect any considerations involving issues under the State Environmental Policy Act (SEPA). The City's responsible official will continue to make all necessary SEPA decisions when individual proposals are submitted.

4. CONFLICTING PROVISIONS

The standards, procedures, and requirements of these Design and Construction Standards are the minimum necessary to promote the health, safety, and welfare of the residents of the City of Granger. The City may adopt more rigorous or different standards, procedures, and requirements whenever necessary. If the provisions of these Design and Construction Standards conflict with one another, or if a provision of these Design and Construction Standards conflicts with the provision of the City Code or another Ordinance of the City, the most restrictive provision or the provision imposing the highest standard shall prevail.

5. SEVERANCE

If any provision of these Design and Construction Standards or its application to any person or circumstance is for any reason held to be invalid, the remainder of these Design and Construction Standards or the application of the provisions is not affected.

6. PROCESS

Design Phase

Any person, firm, or corporation (the "Developer") whom intends to construct a public works improvement shall apply to the City Public Works Director. The request by the Developer shall include a map showing the area to be served; the number and type of proposed units, or the type and size of the proposed facility and a general layout of the development.

Upon receipt of the design requirements from the Public Works Director, the Developer shall employ a Civil Engineer licensed by the State of Washington to prepare plans and specifications for the public works improvements in accordance with these Design and Construction Standards and the Granger Municipal Code. The Developer or its Consulting Engineer shall submit two (2) paper sets of plans and specifications for review by the City and/or the City's Engineer.

The City shall review the initial submittal and indicate corrections or additions or request additional information and return one "red-lined" set to the Developer. The Developer shall make the required corrections and resubmit one (1) paper set of revised plans and specifications to the City Public Works Department.

When it has been determined the plans and specifications indicate compliance with City of Granger Design and Construction Standards, the Developer shall submit to the City the original plan tracings and specifications for final approval. The cover sheet of the original plans shall contain an approval signature block as specified in CHAPTER 2, Section 2. The City's responsible official will sign the plans. Such approved plans and specifications shall not be changed, modified, or altered without authorization from the City Public Works Director. The Developer shall provide the City with a minimum of two (2) copies of the approved plan set and specifications for use by City Inspectors and City Departments as required.

Upon receipt by the Public Works Director of the plan review fee, as discussed in CHAPTER 1, Section 8, the approved original plans and specifications will be returned to the Developer.

Construction Phase

Before the Developer's Contractor commences any work, he shall be required to attend a Preconstruction Conference with the City Public Works Department, the City's Engineer, and utility companies as determined by the City of Granger. The Contractor will submit his insurance and construction schedule at this meeting.

All construction shall be inspected by the City of Granger or its authorized agent. The Contractor shall give ten (10) days minimum prior notice to the Public Works Director the start of any construction activities.

After cleanup by the Contractor and final inspection by the City, the City will calculate the inspection fees and submit them to the Developer. The Developer will pay the inspection fee, as discussed in Section 8, to the Public Works Department.

7. ENGINEERING DESIGN PLAN REQUIREMENTS

All plans, specifications, engineering calculations, diagrams, details, and other relevant data shall be designed and prepared by a Civil Engineer licensed by the State of Washington (Consultant), in accordance with CHAPTER 2.

8. PLAN REVIEW AND INSPECTION FEE

Plan review and inspection fees are hereby established to defray the administrative expense of plan review and inspection costs incurred by the City of Granger.

The plan review and inspection fee shall be the total actual costs incurred by the City of Granger, its agents, employees, and elected or appointed officials, for review and approval of the plans and specifications and for inspection of construction of the public works improvements. The fee shall include, but not be limited to, initial plan review, subsequent meetings with the Developer, explanations to the Developer's engineering consultant, reviews of revised plans, construction inspection, re-inspections, and a final inspection prior to the expiration of the maintenance period.

The plan review fee shall be tabulated and sent to the Developer and paid by the Developer in full prior to the City releasing the approved original plans and specifications for construction or the issuance of a Building Permit.

The construction inspection fee shall be tabulated and sent to the Developer and paid by the Developer in full prior to the City issuing a Certificate of Occupancy or final acceptance of the public works improvements.

9. RECORD DRAWINGS

The Developer's Consulting Engineer shall prepare and maintain a neatly marked, full-sized print set of record drawings showing the final location and layout of all new construction of the public facilities. Prior to final acceptance by the City of Granger, one (1) set of reproducible Record Drawings, one (1) CAD file compatible with AutoCAD version 2010 or newer, and two (2) sets of prints prepared by the Developer's engineer and clearly marked "Record Drawings" shall be delivered to the Public Works Director for review and acceptance.

10. TRANSFER OF OWNERSHIP

The Developer shall complete a Transfer of Ownership of Utility System Form upon completion of the construction of the public works improvements and pending acceptance by the City. This form may be found in Appendix A.

11. EASEMENTS

Public utility easements shall be established for the location of new and future public improvements serving new land divisions and land developments. Easements shall also be granted across the front of new lots and existing lots to provide future utility access as required.

All easements required shall be prepared by the Developer on the proper form and format for recording at the Yakima County Auditor's Office. The easement legal description shall be prepared by a land surveyor licensed in the State of Washington. The executed and notarized easement document shall be submitted to the Public Works Director for recording.

Ten (10) foot wide utility easements shall be dedicated along the front of each lot in subdivisions and short subdivisions. Easements for new and/or future utility lines shall be a minimum of ten (10) feet wide, provided the width of the easements for buried utilities will be at least twice the depth of the planned excavation.

Utility easements shall be continuous and aligned from block to block within a subdivision and with easements in adjoining subdivisions to facilitate the extension and future extension of public utilities.

CHAPTER 2 – GENERAL PLAN REQUIREMENTS

All plans, details, specifications, engineering calculations, diagrams, and other relevant data shall be designed and prepared by a Civil Engineer licensed by the State of Washington.

GENERAL PLAN FORMAT

1. Plan sheets and profile sheets or combined plan and profile sheets and detail sheets shall be on a sheet size of 24" x 36" or 22" x 34".
2. The Cover sheet shall contain the following:
 - a. Name, address, and phone number of the owner/developer;
 - b. Name, address, phone number and stamp of the Civil Engineer preparing the plans (Consultant);
 - c. "APPROVED FOR CONSTRUCTION BY THE CITY OF GRANGER" with signature block for City final approval of the plans;
 - d. Vicinity map showing the project site location;
 - e. An overall site plan;
 - f. Sheet Index;
 - g. Applicable project information; and
 - h. The utility locate call # 1-800-424-5555 or 811.
3. Each sheet shall contain the following project information:
 - a. Project title and City project number, work order number, or LID number, if appropriate;
 - b. Quarter section, Section – Township – Range;
 - c. Sheet title;
 - d. Page (of page) numbering;
 - e. Revision block;
 - f. Subdivision or short plat name.
4. All plan sheets must have a NORTH arrow preferably pointing to the top of the sheet or to the right, and must indicate the drawing scale. All engineering plans must be drawn to an appropriate engineer's scale. For profiles, the vertical scale shall be 1"=2', 1"=5' or 1"=10'. The horizontal scale shall be the same for both plan and profile and shall normally be 1"=20'. Plan and profile stationing shall generally read left to right.
5. The vertical Datum for all plan submittals must be based on the North American Vertical Datum of 1988 (NAVD88). The benchmark used shall be referenced on the plans. An assumed datum will not be accepted.
6. Existing features and topography within the project construction limits must be shown on the plans. This shall include existing road width and surfacing, utility poles, existing underground utilities and surface appurtenances, significant trees, landscaping, and other elements that may affect design/construction.
7. Plan sheets shall indicate all adjacent property lines, right-of-way lines, and easements.
8. Plan sheets shall show all horizontal survey control as required to properly locate and tie the improvements in horizontal location.

WATER SYSTEM PLAN REQUIREMENTS

See CHAPTER 4 for specific design requirements.

1. Show all existing and proposed water system features if known, including but not limited to:
 - a. Water mains;
 - b. Water valves;
 - c. Water meters;
 - d. Water service lines;
 - e. Fire hydrants;
 - f. Blow offs;
 - g. Air and vacuum release valve assemblies;
 - h. Pressure reducing valves;
 - i. Fire sprinkler system lines;
 - j. Double check valves;
 - k. Post indicator valves;
 - l. Thrust blocking.
2. Indicate all easements required for the water main extensions and future extensions.
3. Show the water system and the sanitary sewer system on the same plan and profile view for verification of minimum separation requirements. The design information for each system may be on individual drawings for that system.
4. Show the length, size, and pipe type for all main extensions, fire sprinkler system services, and domestic services where applicable.
5. Identify all joint connections; provide detail of all non-standard joints.
6. Show by station or dimension the location of all fire hydrants, tees, crosses, and services relative to centerline or property lines.
7. A profile view shall be shown for all City water main extensions, aligned if practical with the plan view. Clearly indicate the horizontal and vertical scales.
8. Show the minimum cover and minimum separation on each sheet.
9. In the profile view, show all utilities crossing the proposed water main.

SANITARY SEWER SYSTEM PLAN REQUIREMENTS

See CHAPTER 5 for specific design requirements.

1. Show all existing and proposed sanitary sewer system features including, but not limited to, the following:
 - a. Sewer mains, gravity and force mains;
 - b. Side service, proposed locations;
 - c. Manholes;
 - d. Clean outs;
 - e. Pump stations.
2. Indicate all easements required for the sanitary sewer main extensions and laterals.
3. Provide an overall site plan of development with contours, to show all lots/parcels will be served by the proposed sewer system at design depth for all new development.
4. Show the sanitary sewer system and water system on the same plan and profile for verification of minimum separation requirements. The design information for each may be on individual drawings for that system.
5. Slope, length, size, and pipe type shall be indicated for all lines and side sewers. Pipe length shall be measured from centerline of manholes.
6. Provide a profile for each sanitary sewer main extension. Clearly indicate the vertical and horizontal scale. Show the profile on the same sheet with, and aligned underneath, the plan view as practical.
7. The plan and profile must show the location of all existing and proposed gas, water, irrigation, storm drain, and other utility lines and crossings.
8. Generally show all vertical data in the profile view and all horizontal data in the plan view. It is not desirable to repeat the vertical data in the plan view unless it does not show in a profile.
9. Each manhole shall be uniquely numbered and shall be stationed off of a referenced centerline. Indicate rim and invert elevations in and out at all manholes. Indicate the length of each side sewer stub, the centerline stationing for each side sewer, and the size.

STORMWATER SYSTEM PLAN REQUIREMENTS

See CHAPTER 6 for specific design requirements.

1. Show all existing features if known and all proposed storm sewer (drain) system features, including but not limited to:
 - a. Storm drain mains and lines;
 - b. Catch basins;
 - c. Inlets;
 - d. Drywells;
 - e. Infiltration trenches;
 - f. Retention systems;
 - g. Biofiltration swales;
 - h. Culverts;
 - i. Streams;
 - j. Ditches;
 - k. Natural drainage swales;
 - l. Headwalls;
 - m. Oil/water separator assembly;
 - n. Other requirements of the Department of Ecology Stormwater Management Manual for Eastern Washington.
2. Indicate all grate, rim, and invert elevations in the profile view.
3. Provide stormwater runoff and drainage facilities sizing calculations as described in CHAPTER 6.
4. Indicate all easements required for the storm drainage system.
5. The plan shall clearly indicate the location of the storm drainage items stationed from a referenced centerline.
6. Show all horizontal measurements and control in the plan view.
7. Show slope, length, size and pipe material for all storm drain mains and lines.
8. All catch basins and inlets shall be uniquely numbered and shall be clearly labeled. Stationing and offsets shall be indicated from referenced centerline. Show all proposed storm drain features within the right-of-way in a profile.
9. Generally show all vertical data in the profile view and all horizontal data in the plan view. It is not desirable to repeat the vertical data in the plan view unless it does not show in a profile.

STREET PLAN REQUIREMENTS

See CHAPTER 7 for specific design requirements.

1. Provide a Plan and Profile of all new public roadways or extensions of existing roadways. Provide topography within R/W including utilities. Indicate all horizontal and vertical curve data, percent of grade, bearings, centerline stationing every 50 feet, finish grade elevations, and existing ground line. The profile of the existing centerline ground should extend a minimum of 25 feet before the beginning and at the end of the proposed improvements to show the gradient blend.
2. Provide a cross section or typical section of all rights of way indicating right-of-way width, centerline, pavement width, super-elevation or crown, sidewalk, street lights, curb and gutter, pavement, and base thickness of proposed section.
3. Show all existing and proposed roadway improvements, including but not limited to:
 - a. Pavement and edge of pavement;
 - b. Concrete curb and gutter;
 - c. Sidewalk(s);
 - d. Utilities (manholes, utility poles, pedestals, valves, water meters, etc.);
 - e. Sidewalk ramps;
 - f. Signs and barricades;
 - g. Driveways;
 - h. Rockery or retaining walls;
 - i. Mailboxes;
 - j. Monuments;
 - k. Streetlights, conduit junction boxes, and service cabinet;
 - l. Compliance with ADA requirements.
4. Align the profile view with the plan view, if practical. Clearly indicate the horizontal and the vertical scale.
5. Show all Right-of-Way (R/W) lines, centerlines, and roadway widths for all rights of way.
6. Clearly differentiate between areas of existing pavement, areas of new pavement, and areas to be overlaid.
7. Clearly label all profiles with respective street names and plan sheet reference numbers if drawn on separate sheets.
8. For developments where road work is required on an existing street, development plans are required to include cross section of the existing street and spot elevations at proposed intersections and appurtenances to the project.

CHAPTER 3-GENERAL REQUIREMENTS FOR ALL PROJECTS

FORWARD

The City of Granger has adopted the latest edition of the *Standard Specifications for Road, Bridge and Municipal Construction* prepared by the Washington State Department of Transportation (WSDOT), and the American Public Works Association (APWA) General Special Provisions (GSP's) for Division One General Requirements as the standard specifications governing all design and construction of public works improvements by the City and by private developers.

All references hereinafter made to the "Standard Specifications" shall refer to the latest edition of the Standard Specifications described above. Except as may be amended, modified, or supplemented hereinafter, each section of the Standard Specifications shall be considered as much a part of these requirements as if they were actually set forth herein.

The Standard Specifications, General and Project Special Provision, and the City Standard Details contained in these Design and Construction Standards shall apply in their entirety to all City of Granger public works projects. These Design and Construction Standards have been prepared to form a compiled document intended to assist and inform developer, consultants, and contractors of the construction requirements to be used on proposed public works improvements.

The Standard Specifications, General and Project Special Provision, and City Standard Details shall periodically be amended, revised and updated. It shall be the responsibility of each user of this information to verify that he has the latest revision prior to submitting any work covered by these specifications and details.

Developers and contractor are encouraged to contact the City of Granger Public Works Director to obtain a copy of these standards.

GENERAL

All work shall be done in accordance with the approved Plans, the latest edition of the *Standard Specifications for Road, Bridge, and Municipal Construction* prepared by the Washington State Department of Transportation, amendments to the Standard Specifications, referenced codes and organizations, and these Special Provisions.

The American Public Works Association (APWA) General Special Provisions (GSP's) to Division One of the WSDOT Standard Specifications shall amend Division One of the *Standard Specifications for Road, Bridge, and Municipal Construction*. These GSP's are available at www.wsdot.wa.gov/partners/apwa/.

All materials incorporated into a proposed public works improvements project shall meet the requirements of Division 9 of the Standard Specifications or City of Granger Design and Construction Standards as shown in the Standard Details and Special Provisions.

Any Public Works facility improvements or components that are not specifically addressed in these Design and Construction Standard shall be designed by a professional engineer and provided to the City for review by the City Engineer and approval.

1-01 DEFINITION OF TERMS

1-01.3 Definitions

The terms defined in Section 1-01.3 of the Standard Specifications shall be further described by the following:

City:	Means the City of Granger, a municipal corporation, as represented by its authorized officials, employees or agents.
Construction Documents:	Means the project plans, specifications, and special provisions prepared by the Developer's Consultant for the public works improvements contemplated and approved by the City.
Consultant:	Means an engineer licensed in the State of Washington, employed by the Developer to design the improvement and prepare plans and specifications, perform construction staking, or similar services.
Contractor:	Means the person or firm employed by the Developer or under Contract with the City to do the construction of the public works improvements.
Developer:	Means the person or firm constructing the new development and engaging the services of and employing consultants, and/or contractors and paying for the design and construction of the public works improvements to be transferred to the City.
Drawings:	Means the construction plans prepared by the Developer's Consultant for the public works improvements contemplated. The terms "Construction Documents," "Contract Documents," "Plans," "Engineer's Plans," "Engineer's Drawings," "Working Drawings," and "Project Manual" are synonymous.
Engineer:	Means the appointed City Engineer for the City of Granger or his/her duly authorized agent or representative.
Owner:	Means the City of Granger acting through its legally established officials, boards, commissions, etc., as represented by its authorized officers, employees, or agents.
Public Works Director:	Means the appointed official for the City, responsible for managing the Department of Public Works.

- Special Provisions: The Special Provisions supplement or modify the Standard Specifications and supersede any conflicting provisions of the *Standard Specifications for Road, Bridge, and Municipal Construction* and the appended amendments to the Standard Specifications and are made a part of the Construction Document.
- Standard Details: Means the specific drawing adopted by the City of Granger and revised as necessary which show frequently recurring components of work which have been standardized for use.
- Standard Specifications: The latest edition of *Standard Specifications for Road, Bridge, and Municipal Construction* prepared by the Washington State Department of Transportation, and amendments, and the APWA GSP's for Division One that are, by this reference, made part of the Contractor Documents. Except as may be amended, modified, or supplemented hereinafter, each section of the Standard Specifications shall be considered as much a part of these Construction Documents as if they were actually set forth herein.

Should any conflicts be encountered, the following inter-relationships shall govern: The Special Provisions shall supersede the APWA GSP's, which shall supersede the WSDOT Amendments, which shall supersede the Standard Specifications.

1-03 AWARD AND EXECUTION OF CONTRACT

1-03.4 Contract Bond

Supplement this section with the following:

The Developer/Contractor shall guarantee the material provided and workmanship performed under the Contract for a period of one year from and after the final acceptance thereof by the Developer and the City of Granger. The Developer guarantee shall be confirmed via a subdivision or performance bond issued by a surety company acceptable to the City.

1-04 SCOPE OF WORK

1-04.4 Changes

Supplement this section with the following:

No changes in the work covered by the approved Construction Documents shall be made without having prior written approval of the Developer and the City.

1-05 CONTROL OF WORK

1-05.6(1) (New Section)

The following new section shall be added to the Standard Specifications:

The Contractor/Developer shall be responsible for scheduling and paying for all material and compaction testing required by these Design and Construction Standards for new public works improvements. All Testing services shall be performed by an independent, certified testing firm and/or laboratory meeting the approval of the City. The Contractor shall submit information relating to the qualifications of the proposed testing firm to the City for review and approval prior to the preconstruction conference. The testing service shall provide copies of all test results to the city immediately after completion. The testing frequencies listed below may be modified to assure compliance with the Specifications.

Trench Backfill

Copies of moisture-density curves for each type of material encountered and copies of all test results shall be provided to the City as construction progresses.

Compaction tests shall be taken at a frequency and at depth sufficient to document that the required density has been achieved. At a minimum, one (1) compaction test shall be taken for each 100 linear feet of mainline trench, and one (1) test for each street crossing. At alternating 100 foot locations along the trench line, tests shall be taken at varying depths.

The City may require additional tests be performed at the Contractor's/Developer's expense, if test results do not meet the required trench backfill densities.

All trenches shall be backfilled and compacted to at least 95 percent of maximum density as determined by ASTM D 1557 (Modified Proctor).

Roadway Subgrade (Embankment and Excavation Sections)

Copies of moisture-density curves for each type of material encountered and copies of all test results shall be provided to the City as construction progresses.

Compaction tests shall be taken at a frequency sufficient to document that the required density has been achieved. At a minimum, one (1) compaction test shall be taken for every 100 linear foot of road lane or equivalent.

The City may require additional tests be performed at the Contractor's expense, if test results do not meet the required subgrade densities. Subgrade compaction shall be as specified for Roadway Embankment Section 2-03.3(12) and Subgrade Preparation Section 2-06.

Ballast and Crushed Surfacing

Copies of moisture-density curves and gradation for each type of material incorporated into the project and copies of all test results shall be provided to the City as construction progresses.

Compaction tests shall be taken at a frequency sufficient to document that the required density has been achieved. At a minimum, one (1) compaction test shall be taken for every 100 linear foot of road lane or equivalent for each lift of ballast or crushed surfacing.

The City may request additional tests be performed at the Contractor's/Developer's expense, if test results do not meet the required subgrade densities.

Compaction of ballast and crushed surfacing shall be as specified in Section 2-03.3(14).

Asphalt Pavement

Copies of the reference maximum density test for each class of Hot Mix Asphalt pavement and copies of all test results shall be provided to the City as construction progresses.

Hot Mix Asphalt shall be accepted on a lot basis. A lot shall consist of 400 tons of Hot Mix Asphalt or a day's worth of paving, whichever is smaller.

Density tests shall be taken at a frequency sufficient to document that the required density has been achieved. At a minimum, five (5) compaction tests shall be taken for every lot of 400 tons, with a minimum of five (5) compaction tests per day.

The City may request additional tests be performed at the Contractor's/Developer's expense, if test results do not meet the required densities.

Compaction of Hot Mix Asphalt pavement shall be as specified in Section 5-04.3(10)B.

Cement Concrete Curb, Gutter and Sidewalk

A copy of the cement concrete mix design or certification from the concrete supplier that the concrete provided has been prepared to the strength requirement as specified elsewhere in these specifications.

Concrete strength cylinders shall be taken and tested at a minimum of one set of four (4) cylinders per day or per 100 cubic yards placed, whichever is more. Slump, air and temperature tests shall be taken at the same intervals as strength cylinders are taken.

Copies of all test results shall be provided to the City as construction progresses.

1-05.10 Guarantees

Delete this section and replace it with the following:

If, within one (1) year after the date of Final Acceptance of the Work, defective and unauthorized materials or work is discovered, the Contractor shall promptly, upon written request, return and in accordance with the instructions either correct such work, or if such work has been rejected, remove it from the Project Site and replace it with non-defective and authorized work, all without cost to the City. If the Contractor does not promptly comply with the written request to correct defective and unauthorized work, or if an emergency exists, the City reserves the right to have defective and unauthorized work corrected or rejected, removed and replaced pursuant to the provisions of Section 1-05.7 of the Standard Specifications.

The Contractor agrees the above one-year limitation shall not exclude nor diminish any rights under any law to obtain damages and recover costs resulting from defective and unauthorized work discovered after one year.

1-05.16 Water and Power (New Section)

The following new section shall be added to the Standard Specifications:

Water Supply: Water for use on the projects may be obtained/purchased from the City of Granger and the Contractor shall arrange for and convey the water from the nearest convenient hydrant or other source at his own expense. A refundable deposit shall be made with the City Clerk's office to secure a hydrant meter from the Public Works Department. The hydrants shall be used in accordance with the City of Grandview Water Department regulations.

The City reserves the right to deny the use of fire hydrants where deemed inappropriate by the City.

Power Supply: The Developer shall make necessary arrangements, and shall bear the costs of power necessary for the performance of the work.

1-07 LEGAL RELATION AND RESPONSIBILITIES TO THE PUBLIC

1-07.1 Laws to be Observed

Amend the second sentence of the first paragraph to read:

The Contractor/Developer shall indemnify and save harmless the City of Granger (including any agents, officers, employees and representatives) against any claims that may arise because the Contractor (or any employee of the Contractor or subcontractor or materialman) violated a legal requirement.

1-07.5(3) State Department of Ecology

Add the following:

9. Comply with the requirements and special general conditions of the Construction Stormwater General Permit issued by the Washington State Department of Ecology to the Developer/Contractor for this project.

1-07.5(4) Air Quality

Supplement this section with the following:

The Contractor shall comply with the environmental provisions of local air pollution authorities, Yakima County Clean Air Authority.

A method of dust control during construction shall be submitted to, and approved by, the Yakima County Clean Air Authority. A written copy of their approval shall be submitted to the Public Works Director prior to commencement of construction. The Contractor/Developer shall designate a project coordinator for contact during construction regarding alleged air quality violations and other complaints.

1-07.13 Contractor's Responsibility for Work

1-07.13(1) General

Supplement this section with the following:

The Contractor shall keep the City of Granger, the Developer, and the Consultant informed in writing of the address to which official correspondence is to be directed, the address and phone number of the person in charge of his field personnel, and the address and telephone number of the Contractor's representative who will be responsible and available outside of normal working hours for emergency repairs and the maintenance of traffic control and safety devices.

1-07.17 Utilities and Similar Facilities

Supplement this section with the following:

It shall be the Contractor's responsibility to investigate and verify the presence and location of all utilities prior to construction.

The Contractor/Developer shall call for field location, not less than two nor more than ten business days before the scheduled date for commencement of excavation which may affect underground utility facilities, unless otherwise agreed upon by the parties involved. A business day is defined as any day other than Saturday, Sunday or legal local, state or federal holiday. **The phone number for the Northwest Utility Notification Center for Granger is 1-800-424-5555, or 811.** If no one-number locator service is available, notice shall be provided individually by the Contractor to those owners known to or suspected of having underground facilities within the area of proposed excavation.

The Contractor/Developer is alerted to the existence of Chapter 19.122 RCW, a law relating to underground utilities. Any cost to the Contractor/Developer incurred as a result of this law shall be at the Contractor's/Developer's expense.

No excavation shall begin until all know facilities, in the vicinity of the excavation area, have been located and marked.

1-07.18 Public Liability and Property Damage Insurance

Supplement this section with the following:

The Contractor shall obtain and maintain in full force and effect during the duration of this Contract public liability and property damage insurance in accordance with this section and as modified herein.

Prior to commencing construction, the Contractor/Developer shall furnish the City of Granger a Certificate of Insurance and the additional insured endorsements as evidence of compliance with these requirements. The certificate shall name the **City of Granger, its employees, agents, elected and appointed officials, engineering consultant, and all subcontractors** as "additional insureds" and shall stipulate that the policies named thereon cannot be canceled unless at least forty-five (45) days written notice has been given to the City of Granger. The certificate shall not contain the following or similar wording regarding cancellation notification: **"Failure to mail such notice shall impose no obligation or liability of any kind upon the company, its agents, or representatives."**

1-08 PROSECUTION AND PROGRESS

1-08.3 Progress Schedule

Supplement this section with the following:

Prior to the commencement of any work, a preconstruction conference shall be held. The Contractor or Developer shall contact the City of Granger and set a date and time for the meeting. It shall be the responsibility of the Contractor/Developer to notify and invite all parties having an interest in the project to the meeting, including the major subcontractors, Fire District, Irrigation District, and private utilities.

At this conference all points of the approved Plans and Specifications will be open to discussion including scope, order and coordination of work, equipment lead time required, means and methods of construction, inspection and reporting procedures, etc. The Contractor should satisfy himself that all provisions and intentions of the work are fully understood.

The Contractor shall prepare and submit to the City and Developer at the preconstruction conference a Construction Progress and Completion Schedule using a bar graph format. Items in the Schedule shall be drawn to a time scale, shown along the base of the diagram, using an appropriate measurement per day with weekends and

holidays indicated. The Construction Progress Schedule shall be continuously updated and, if necessary, redrawn upon the first working day of the month or upon issuance of any Change Order which substantially affects the scheduling. Copies (2 prints and 1 reproducible) of newly updated Schedules shall be forwarded to the City, as directed, immediately upon preparation.

1-10 TEMPORARY TRAFFIC CONTROL

Supplement this section with the following:

The provisions of the latest edition of the *Manual on Uniform Traffic Control Devices* (MUTCD) for Streets and Highways and amendments thereto published by the U.S. Department of Transportation, Federal Highway Administration, and WSDOT by this reference are made a part of these Documents.

1-10.2(2) Traffic Control Plans

Delete the entire section and replace with the following:

The Contractor shall prepare a signing plan showing the necessary Class A and B construction signing, barricades, and traffic control devices required for the project and submit it to the Consultant and City for review no later than the preconstruction conference date. When the Class B signing for a particular area will be provided as detailed on one or more of the figures included in the MUTCD without modification, the Contractor may reference the applicable MUTCD figure at the appropriate location on the Plan. When this procedure is used, variable distances such as minimum length of taper must be specified by the Contractor.

The signing plan prepared by the Contractor shall provide for adequate warning within the limits of the project and on all streets, alleys, and driveways entering the project so that approaching traffic may turn left or right onto existing undisturbed streets before reaching the project. The Plan shall be prepared to create a minimum of inconvenience for pedestrian and vehicle traffic.

All modifications to the accepted signing plans shall be reviewed by the City.

1-10.3(3)A Construction Signs

The first sentence of the first paragraph is revised to read:

All signs, barricades, flashers, cones, traffic safety drums and other traffic control devices required by the approved traffic control plan(s), as well as any other appropriate signs prescribed by the City or County, shall be furnished and maintained by the Contractor.

CHAPTER 4 - WATER SYSTEM IMPROVEMENTS

GENERAL REQUIREMENTS FOR WATER SYSTEM IMPROVEMENTS

All extensions and additions to the City of Granger's domestic water system shall conform to the Design and Construction Standards of the City of Granger and the Washington State Department of Health (DOH) as follows:

All new lots and developments shall be served by a public domestic water supply line to be maintained by the City of Granger and located adjacent to the lot or development site. The water supply line shall be capable of providing sufficient flow and pressure to satisfy the fire flow and domestic service requirements of the proposed lots and development requirements.

Water lines shall be extended by the Developer to the point where the adjoining property owner's responsibility for further extension begins. This typically requires an extension across the entire frontage of the property to the property line of the adjoining owner. In some cases, it will require dedication of an easement and a line extension across the property or extension across two or more sides of the developing property. Extensions will be consistent with and implement the City's adopted Small Water System Management Program.

Cover over new watermains shall be a minimum of 48" and a maximum of 72". All new public domestic water mains shall be a minimum diameter of 8 inches. Fire hydrant runs less than 50 feet from the water main to the fire hydrant shall be a minimum of 6 inches.

Larger public water mains may be required depending upon fire flow requirements as determined by the City of Granger's Public Works Director, Fire Chief, or City Engineer.

Water main oversizing, above that required for the particular development being submitted, may be required by the City of Granger to be installed for future extension. The cost of the materials only for the oversizing shall be reimbursed to the Developer by the City. The Developer shall submit actual material invoices showing the actual cost of the materials furnished and the cost of the same materials of the size required for the development.

All domestic water mains shall be looped, where possible. Temporary dead-end mains over 300 feet in length will only be allowed where future water main looping via public right of way will be assured.

Maximum valve spacing in public water mains will be 800 linear feet. Valves will be furnished and installed on two legs of new water main tees and three legs of new water main crosses. Valve operating nut extensions approved by the City will be required on valves where the operating nut is deeper than 36 inches below finished grade.

All new water meters shall be a minimum of 3/4-inch and shall be furnished and installed by the City of Granger, at the Developer's expense. The Developer will furnish and install all water service components from the water main to the meter setter and from the meter setter to the property line including service saddle, corporation stop, service tap, service

pipe, meter stop, yoke assembly, and meter box, all at the Developer's expense. Only one meter shall be served from each main tap.

All live taps of water mains shall be performed by the City (or City's representative with Public Works Director's approval) using a full circle stainless steel tapping sleeve with gate valve and paid for by the Developer.

Minimum 2-inch air and vacuum release valves shall be furnished and installed at high points in the system.

Maximum spacing of fire hydrants shall be 500 feet in residential areas and 300 feet in commercial areas. Additional hydrants may be required to protect structures as determined by the Fire Chief and Public Works Director. Additional fire hydrants required on a site may require a looped, on-site fire hydrant main. Easements will be provided for all on-site, public, looped water mains, in accordance with CHAPTER 1, Section 11.

Water and sewer mains shall be separated in accordance with Section C 1-9.1 of the *Criteria for Sewage Works Design, August 2008*, by the Washington State Department of Ecology.

The design of water mains and appurtenances is subject to review and approval by the City of Granger Public Works Director. The Public Works Director may, at his discretion, adjust these Design and Construction Standards as necessary to facilitate installation of water lines and appurtenances for the health, safety, and protection of the general public.

All double detector check valve assemblies shall conform to City of Granger standards. Initial and annual testing will be required.

SPECIAL PROVISIONS FOR WATER SYSTEMS

The following sections of the WSDOT Standard Specifications have been amended or supplemented as described below and apply to the construction of public works water system improvements within the City of Granger.

7-09 WATER MAINS

7 -09.2 Materials

Pipe for main line approved for use shall be as follows:

Pipe for Main Line:

Ductile Iron Pipe
Polyvinyl Chloride (PVC) Pressure Pipe

Supplement this section with the following:

Ductile Iron Pipe: Ductile iron pipe shall conform to the requirements of Section 9-30.1 (1) of the Standard Specifications, except that it shall be Standard Thickness Class 50. Joints shall be rubber gasket, push-on type (Tyton Joint). Fittings shall be mechanical

joint or flanged, as shown on the Plans, and shall conform to Section 9-30.2(1) of the Standard Specifications.

Polyvinyl Chloride (PVC) Pressure Pipe: PVC pipe shall conform to the requirements of Section 9-30.1 (5)A. Fittings shall be the same as specified for Ductile Iron pipe. PVC pipe must be provided with detectable marking tape, see Section 7-11.3(10).

Fittings for Main Lines:

Connection Couplings: Couplings for Ductile Iron or PVC pipe, either transition or straight couplings, shall be compression type flexible couplings conforming to Section 9-30.2(7) of the Standard Specifications.

Aggregates:

Gravel Backfill for Pipe Zone: Imported pipe zone material for flexible pipes shall be crushed Surfacing Top Course meeting the requirements of section 9-03.9(3), and shall be placed and compacted in layers as designated by the City. Pipe zone material for rigid pipes shall be Crushed Surfacing Base Course meeting the requirements of Section 9-03.9(3).

Trench Backfill: All longitudinal water main trenches (parallel to curb) shall be backfilled full depth above the pipe zone with native material (free of organic material, wood, rocks, or pavement chunks larger than 6-inches in maximum dimension), unless otherwise directed by the City of Granger. Street crossing trenches and other locations as directed by the City of Granger shall be backfilled full depth with imported select backfill. Imported select backfill shall be crushed surfacing base course, placed and compacted in layers.

7 -09.3 Construction Requirements

7-09.3(5) Grade and Alignment

Replace the first sentence of the third paragraph with the following:

The depth of trenching for water mains shall be such to provide a minimum cover of 4 feet and a maximum cover of 6 feet, unless otherwise approved by the Public Works Director.

7-09.3(9) Bedding the Pipe

Supplement this section with the following:

All construction work shall be inspected by the City or its representative before pipe installation and backfilling. Imported pipe zone bedding/backfill for pipes shall be in accordance with Section 7-09.2 above, placed and compacted per the Standard Specifications. Bedding shall be placed under all pipe.

7-09.3(10) Backfilling Trenches

Supplement this section with the following:

Street crossing trenches, and other locations as directed, shall have the trench backfilled full depth with Imported Select Backfill. The Public Works Director may require the use of Controlled Density Fill (CDF) for trench backfill in certain circumstances. The requirements for CDF are set forth in CHAPTER 7, Section 8-30 of these Special Provisions.

7-09.3(11) Compaction of Backfill

Delete the first paragraph and supplement this section with the following:

Mechanical compaction shall be required for all trenches. The Contractor is hereby cautioned that time extensions shall not be granted due to unstable trench backfill conditions caused by excessive watering. The Contractor shall be responsible for correcting such conditions caused by his own construction activities.

The density of the compacted material shall be at least 95% of the maximum density as determined by ASTM D 1557 Tests (Modified Proctor). The Contractor shall notify the City 24 hours in advance of when they are ready for in-place density tests of the trench line. The Contractor/Developer shall be responsible for scheduling and paying for all compaction testing required. Refer to section 1-05.6(1) of these Design and Construction Standards. Density tests shall be taken at various depths in the trench. The Contractor shall provide a backhoe and operator for the excavation and backfill of test holes. Placement of courses of aggregate shall not proceed until density requirements have been met.

The first 500 feet of trench backfill operations shall be considered a test section for the Contractor to demonstrate his backfilling and compaction techniques. The Contractor shall notify the City at least 3 working days prior to beginning trench excavation and backfill operations and the Contractor will arrange for in-place density tests to be taken on the completed test section in accordance with the above requirements. No further trenching will be allowed until the specified density is achieved in the test section. Passing in-place density tests in the test section will not relieve the Contractor from achieving the specified densities throughout the project.

7-09.3(12)A Locating Wire (New Section)

The following new section shall be added to the Standard Specifications:

A continuous solid copper locating wire shall be placed along the top of all water pipe. This wire shall be secured to the top of the pipe at maximum 10-foot intervals using 6-inch strips of 2-inch wide duct tape. All splices shall be tied, electrically continuous, and made waterproof. Access to terminal ends of the locating wire shall be made at locating wire boxes, per the details shown on the Drawings. The result of this installation shall be a continuous wire circuit electrically isolated from ground. The Contractor shall be responsible for testing continuity and for testing isolation from ground in the wire after all work has been completed on the test section. The Contractor is advised to do intermediate testing on his own after backfilling operations and prior to surface

restoration work to be sure continuity is maintained. If there is a break or defect in the wire, it shall be the Contractor's responsibility to locate and repair the defect. The continuity of the location wire shall be tested from one test load point to the next by use of a temporary wire laid between test points in-line with an ohmmeter. Resistance shall be measured with an approved ohmmeter that has been properly calibrated. The continuity of a test section will be accepted if the resistance of the test section does not exceed 5 ohms per 500 feet of location wire being tested. Isolation from ground shall be measured with a megohmmeter and shall be a minimum of 20 megohms for any section of location wire tested. The City shall witness the acceptance test.

7-09.3(19)A Connections to Existing Mains

Supplement this section with the following:

New water mains shall be tested, flushed, and disinfected per applicable DOH requirements with passing results, prior to making connection to existing main and being placed into operation.

No existing line valves shall be closed without permission by the City of Granger. In no case shall any existing water main valve be closed for a period of greater than eight (8) hours.

7-09.3(23) Hydrostatic Pressure Test

Replace the first sentence with the following:

All water mains and appurtenances shall be tested under a hydrostatic pressure of 200 psi for a fifteen (15) minute period.

7-12 VALVES FOR WATER MAINS

7 -12.2 Materials

Supplement this section with the following:

Gate Valves: All valves sizes 2-inch through 8-inch shall be gate valves manufactured in the U.S. and shall conform to the latest revision of AWWA Resilient Seated Gate Valves Standard C509 and AWWA C104.

All gate valves shall have non-rising stems, open counterclockwise, and shall be provided with a 2-inch square AWWA operating nut. Gate valves 4-inch and larger shall have flanged and/or mechanical joint connections, as shown on the Plans. Stuffing box shall be O-ring type.

Butterfly Valves: All valves sizes 10 inches and larger shall be butterfly valves manufactured in the U.S. and suitable for direct burial and shall be rubber seated and conform to the latest revision of AWWA Standard C504 Class 150B and C104.

Valve operators shall be worm gear type, sealed, gasketed, and lubricated for underground service. All valves shall open counterclockwise and shall be provided with a 2-inch square AWWA operating nut.

Valves shall have mechanical joint and/or flanged connections as shown on the Plans and shall be of the same size as the line on which they are located. Valve shafts shall be a one-piece unit extending full size through the valve disc and valve bearings, with minimum shaft diameter as specified in AWWA C 504 Class 150B. Valve operators shall be worm gear type, sealed, gasketed, and lubricated for underground service. All valves shall open counter-clockwise and shall be provided with a 2-inch operating nut, unless otherwise specified.

Tapping Sleeve and Valve Assemblies: Tapping sleeves shall be full circle, Romac Stainless Steel Tapping Sleeve (SST) with Ductile Iron Flanged Outlet, or approved equal, conforming to the latest AWWA Standard C223.

Valve Boxes shall be two-piece adjustable. The top section shall be similar to Olympic Foundry Model 940-B, or equal, 18-inches high. The bottom section shall be a Olympic Foundry Model R-36, or equal, 36-inches high. Extension sections shall be Olympic Foundry Model 044, or equal, 12-inches high.

7 -12.3 Construction Requirements

Supplement this section with the following:

Valves: Upon completion of all work in connection with this Contract, the Developer/Contractor shall contact the City of Granger Public Works for opening water valves. Valves shall only be operated by City Public Works staff.

Valve Boxes: Valve boxes should be set to position during backfilling operations so they will be in a vertically centered alignment to the valve operating stem. The top of the box will be at final grade.

The Contractor shall adjust all water valve boxes to the final grade of the surrounding area including new concrete sidewalk, asphalt paving, gravel surfacing, or topsoil surfacing, in accordance with the details shown on the Drawings.

The Contractor shall keep the valve boxes free from debris caused by the construction activities. All valve boxes will be inspected during final walk-thru to verify that the valve box is plumb and that the valve wrench can be placed on the operating nut.

7-14 HYDRANTS

7 -14.2 Materials

Supplement this section with the following:

The City of Granger accepts fire hydrants of the following manufacturers, providing the hydrants conform to the City's Design and Construction Standards for fire hydrants:

Mueller Super Centurion A-423
M&H 929 Reliant

All hydrants shall have a Main Valve Opening (MVO) of 5-1/4" and one port with a 5" Storz Quick Coupling and two (2) 2-1/2" diameter ports. Threads on all ports shall be National Standard Thread.

Fire hydrants shall be painted with two coats of high visibility yellow paint.

NON-FREEZE YARD HYDRANT

Non-freeze yard hydrants shall be of the type shown on the Plans, cast iron construction, brass hardware, threaded hose connection, with seat that can be replaced without removing the hydrant from the ground. Yard Hydrants shall be Zurn Z-1395, or equal. Provide 3/4-inch hose connection and 3-foot depth of bury.

7-14.3(1) Setting Hydrants

Delete the first and second paragraphs and replace with the following:

The hydrant shoe shall be set on a concrete block base 12" x 12" x 6" thick, which has been placed on undisturbed earth. Around the base of the hydrant, the Contractor shall place 0.5 cubic yards of washed drain rock ranging in size from 3/4" to 1-1/2", to allow free drainage of the hydrant. The drain rock shall be completely covered with construction geotextile fabric as directed by the City.

The Contractor shall be responsible for verifying the hydrant flange elevations and shall provide additional depth-of-bury hydrants or hydrant extensions to achieve a flange elevation of 3" above the back of curb, sidewalk, or finished grade, as shown on the City's Standard Detail.

Fire hydrants shall be painted with two coats of high visibility yellow paint.

7 -14.3(2) Hydrant Connections

Replace this section with the following:

Hydrant runs of less than 50 feet shall be connected to the main with 6-inch minimum diameter water main. Each hydrant lateral shall include an auxiliary gate valve and valve box.

7 -14.3(2)A Hydrant Restraints

Replace this section with the following:

All hydrants shall be connected to the water main as shown on the City's Standard Detail.

7-14.3(2)C Hydrant Guard Posts

Replace this section with the following:

The Public Works Director may determine that four (4) 6-inch diameter Sch. 40 steel guard posts shall be installed at a hydrant location. Hydrant guard posts shall be painted the same color as the hydrants.

7-15 SERVICE CONNECTIONS

7-15.1 Description

Replace this section with the following:

This work consists of the relocation of existing water meters and water meter boxes, where necessary, and the installation of new saddles, corporation stops, service pipe, water meter box, meter setter, and meter stops as shown on the Plans.

7 -15.2 Materials

Supplement this section with the following:

Saddles: New service saddles shall be Romac Style 202NS.

Corporation Stops: New corporation stops shall be Ford type 1100, for service line size.

Service Pipe: New service pipe shall be CTS Cross-linked Polyethylene (PEX) tubing meeting the requirements of ASTM F876/F877 and ANSI/NSF Standard 14/61 or approved equal.

Meter Stop: New meter stop shall be Ford AV94 angle yoke key valve.

Yoke Assembly: Yoke bar shall be Ford Model 500 Series with wrench type connection. Yoke ell shall be Ford L91 for service line size. Yoke expansion connection shall be Ford EC for service line size.

Double Check Valve: New double check valve assembly for 2-inch service shall be Watts 007 or approved equal.

Meter Boxes: New meter boxes shall be Carson HW Model MSBCF-1324-18 (for 3/4" and 1" meters) and MSBCF-1730-18 (for 2" and larger meters), ductile iron cover (for vehicular traffic areas) and heavy duty plastic covers (for non-vehicular areas) with reader doors.

Pipe Bedding and Backfill: Pipe bedding and select backfill shall be utilized for trench backfill as directed by the City in accordance with Section 7-09.2 of the Special Provisions.

7 -15.3 Construction Requirements

Supplement this section with the following:

The Contractor shall set the water meter box to the finished grade of the area. The Contractor will be required to reset the meter box if it is not at finished grade at the completion of the project. The completed water service shall be tested at system operating pressure by the Contractor and must show no signs of leakage.

Future water services shall be marked with an 18" long section of #4 rebar buried vertically with the top of the rebar set 6" below the finish surface, and a 6-foot 2"x4" post. Refer to City Standard Detail W5.

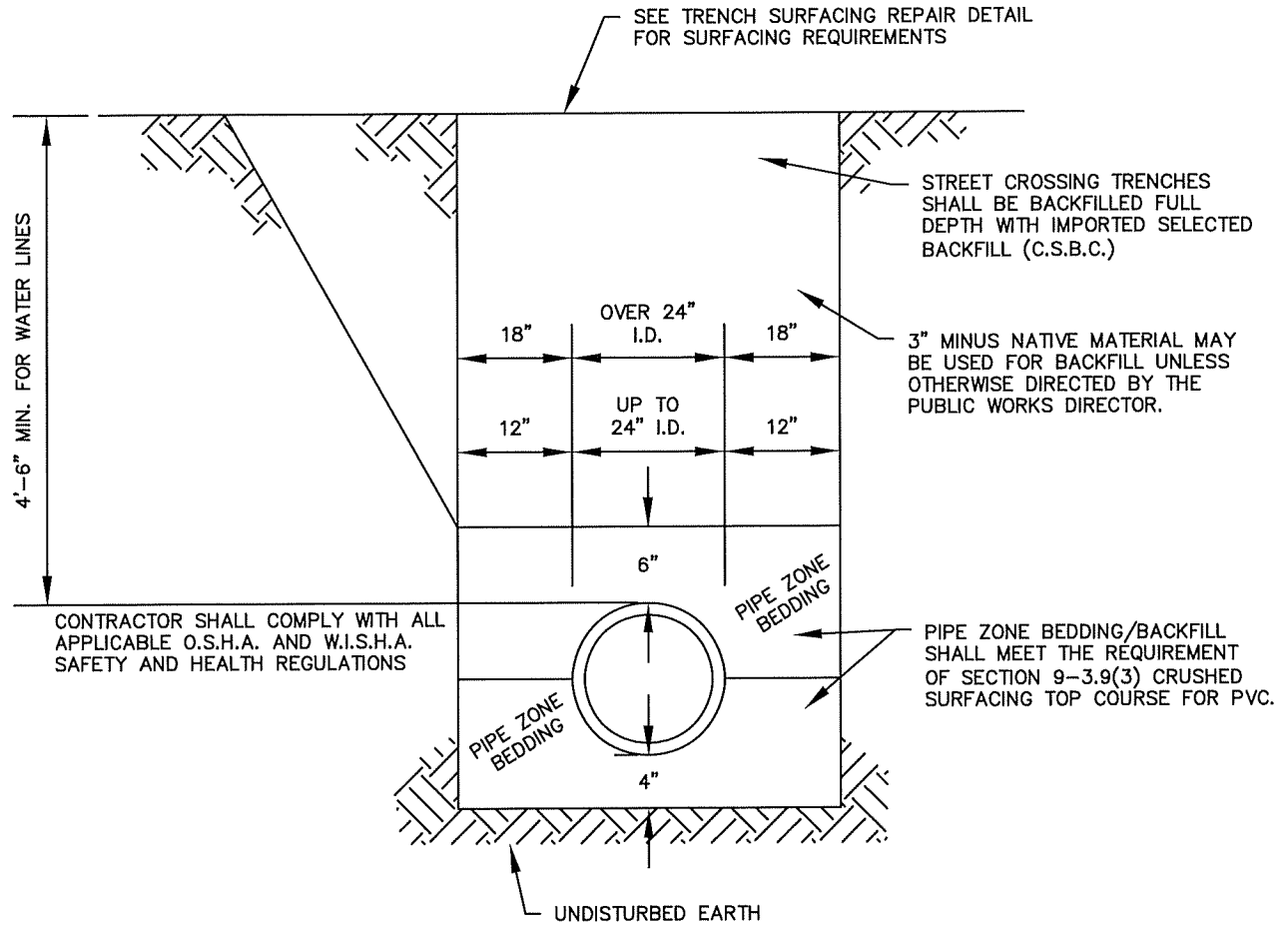

NOTES:

1. FOR WATER SERVICE INSTALL IMPORTED PIPE BEDDING A MINIMUM OF 3" THICK ON ALL SIDES OF PIPE.
2. MECHANICAL TAMPING AND COMPACTION REQUIRED AS DIRECTED BY THE CITY. WATER SETTLING MAY ONLY BE USED OUTSIDE THE ROADWAY PRISM WHEN APPROVED BY THE CITY.
3. ONLY THE LATEST DETAIL, AS APPROVED BY THE DIRECTOR OF PUBLIC WORKS, SHALL BE USED.

ORIG.	3/17	-
REV.	DATE	DESCRIPTION

CITY OF GRANGER—STD. DETAIL

WATERMAIN TRENCH

DWG #

W 1

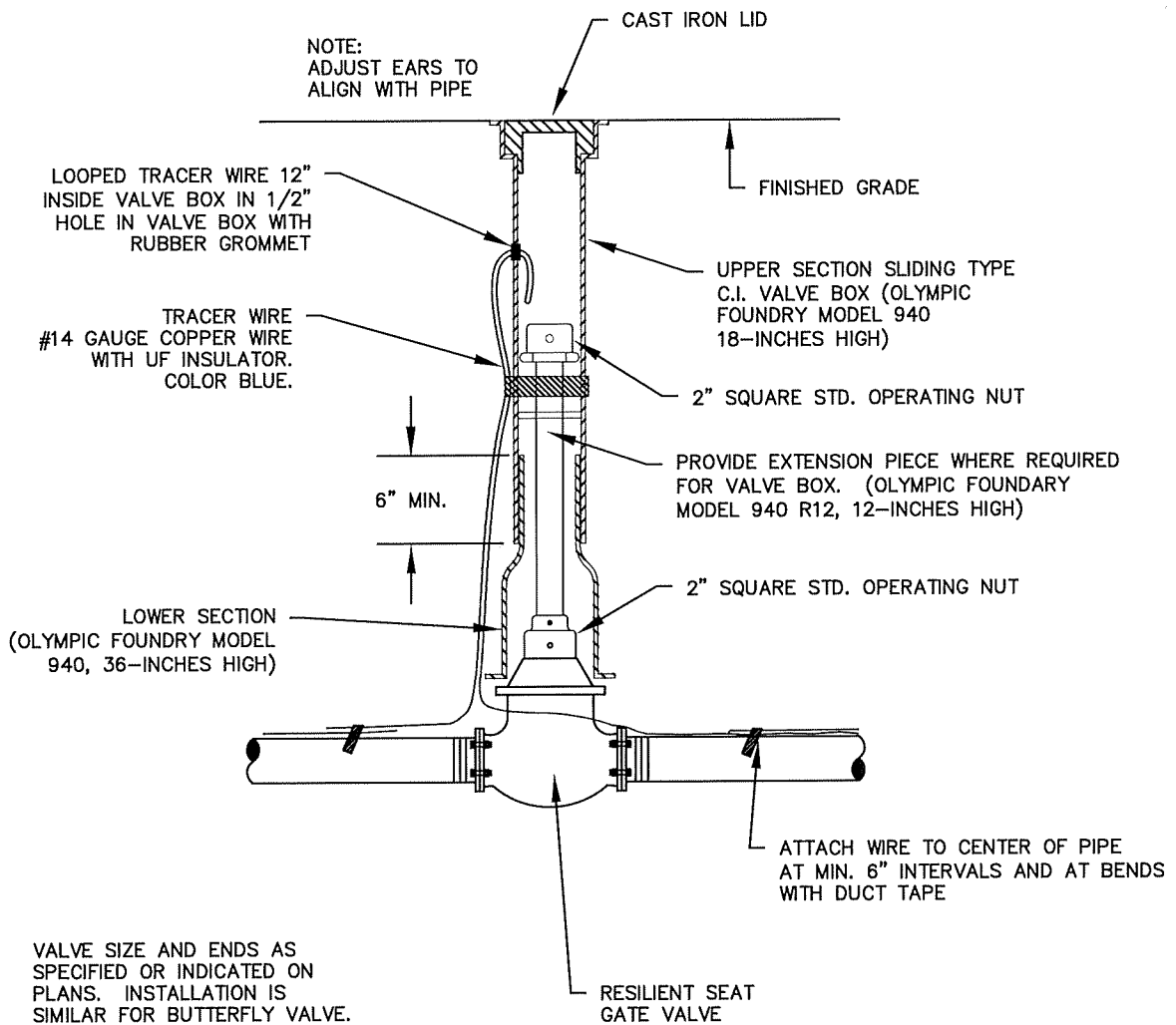

NOTE:

ONLY THE LATEST DETAIL, AS APPROVED BY THE
DIRECTOR OF PUBLIC WORKS, SHALL BE USED.

ORIG.	3/17	-
REV.	DATE	DESCRIPTION

CITY OF GRANGER—STD. DETAIL

WATER VALVE BOX

DWG #

W2

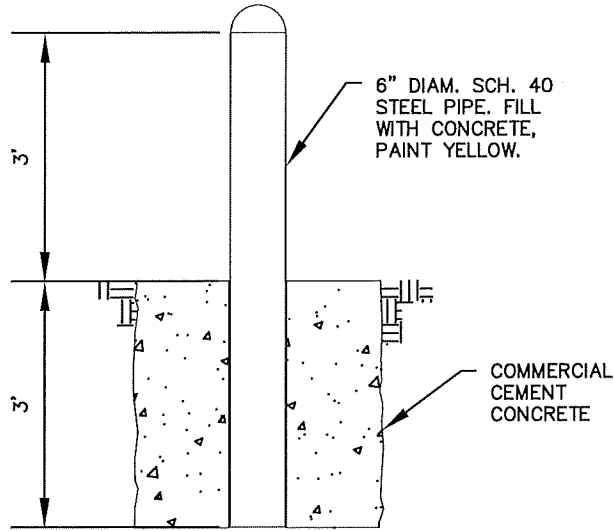

SECTION A-A

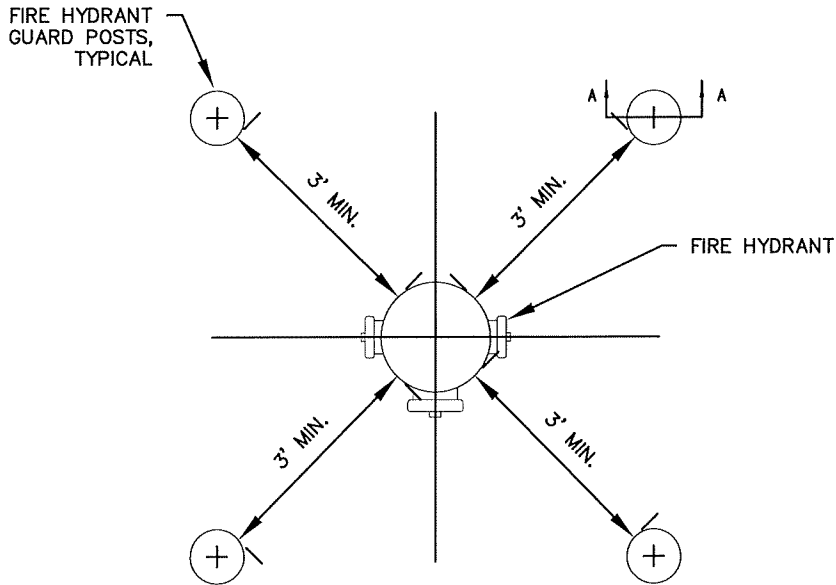

PLAN

NOTE:

ONLY THE LATEST DETAIL, AS APPROVED BY THE DIRECTOR OF PUBLIC WORKS, SHALL BE USED.

ORIG.	3/17	-
REV.	DATE	DESCRIPTION

CITY OF GRANGER—STD. DETAIL

FIRE HYDRANT GUARD POSTS

DWG #

W4

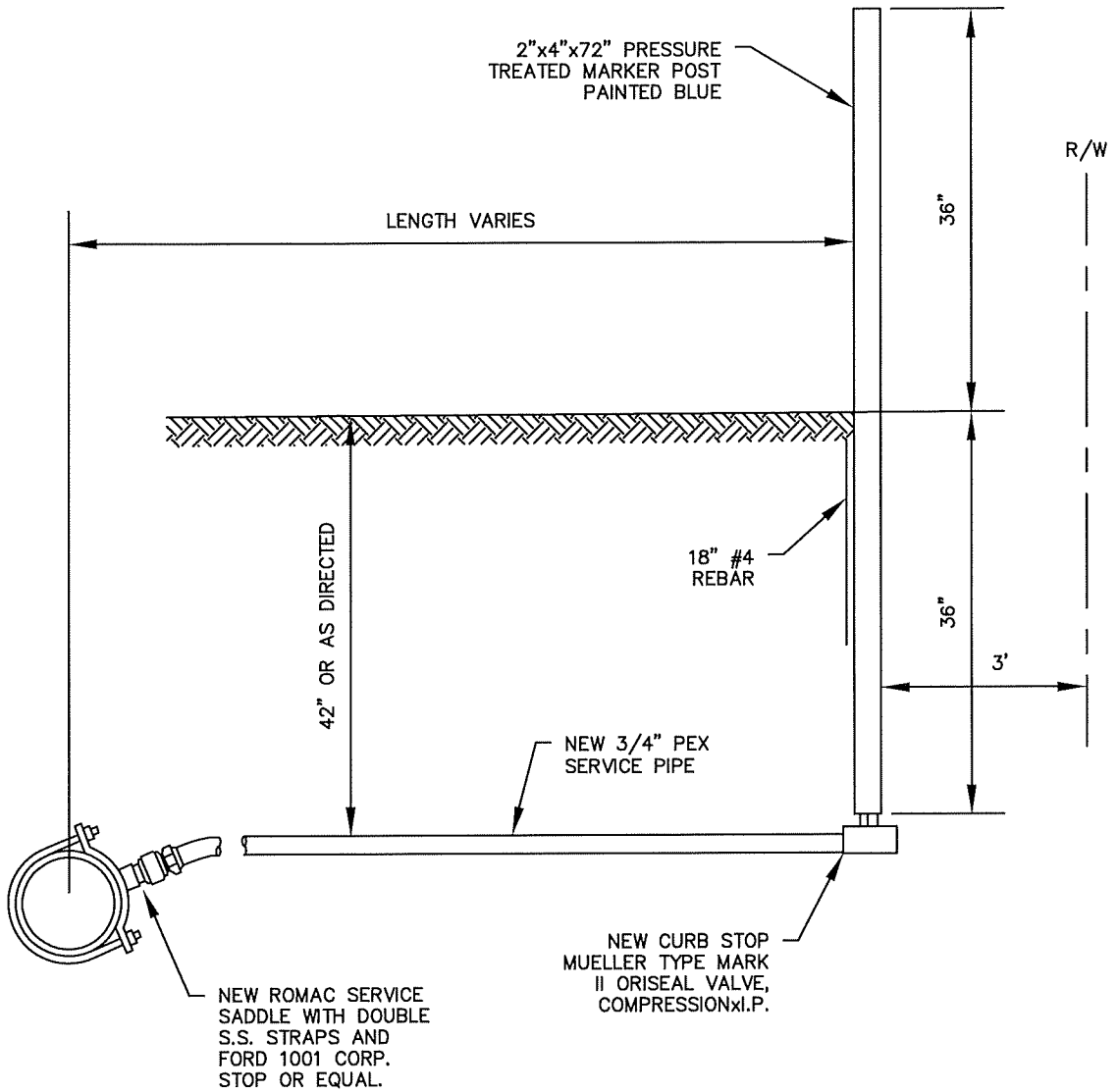

NOTE:

ONLY THE LATEST DETAIL, AS APPROVED BY THE DIRECTOR OF PUBLIC WORKS, SHALL BE USED.

ORIG.	3/17	-
REV.	DATE	DESCRIPTION

CITY OF GRANGER—STD. DETAIL

WATER SERVICE

DWG #

W5

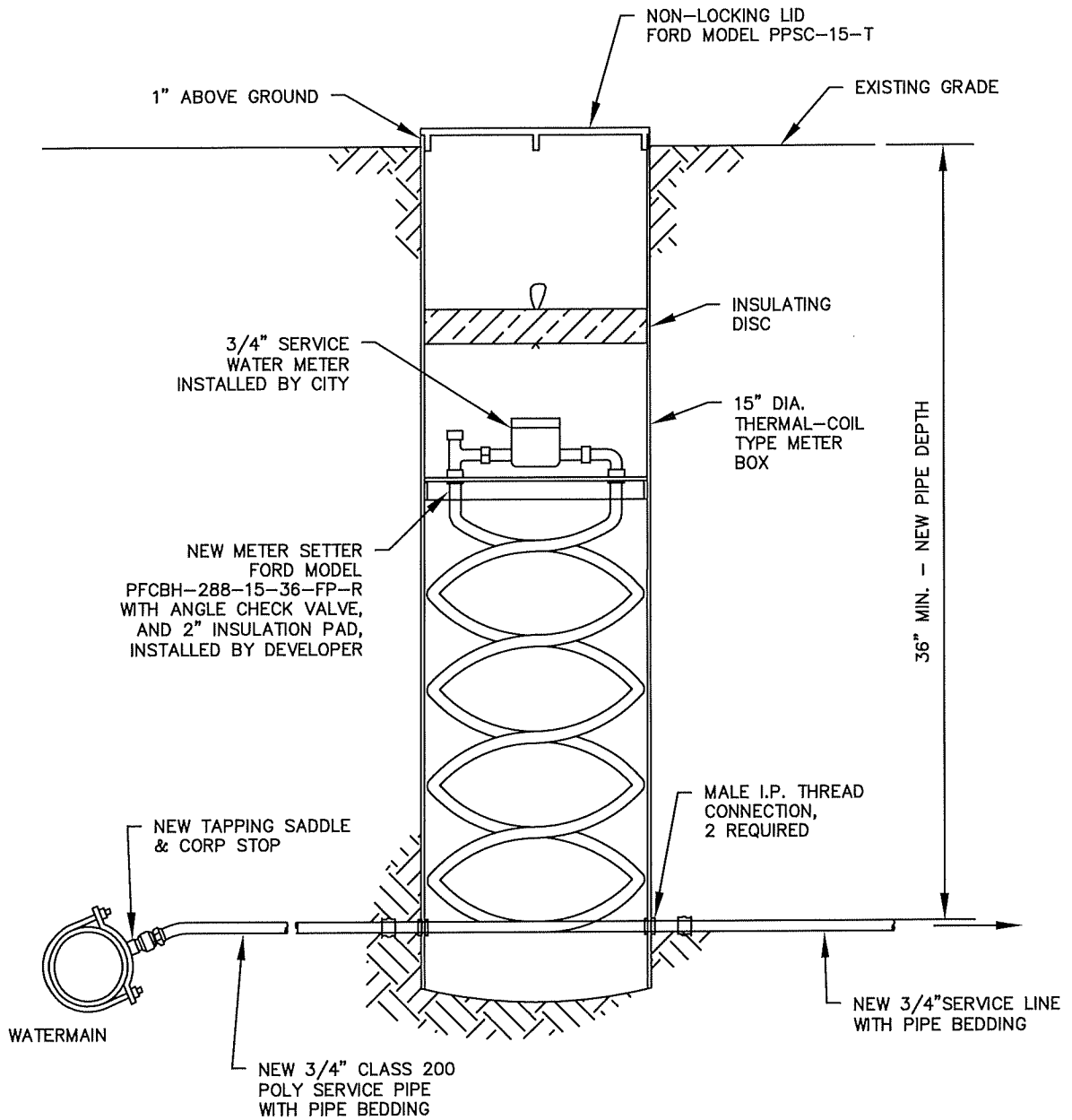

NOTE:

ONLY THE LATEST DETAIL, AS APPROVED BY THE DIRECTOR OF PUBLIC WORKS, SHALL BE USED.

ORIG.	3/17	-
REV.	DATE	DESCRIPTION

CITY OF GRANGER-STD. DETAIL

WATER METER BOX

DWG #

W6

PLAN VIEW

SEE W6 FOR PROFILE VIEW

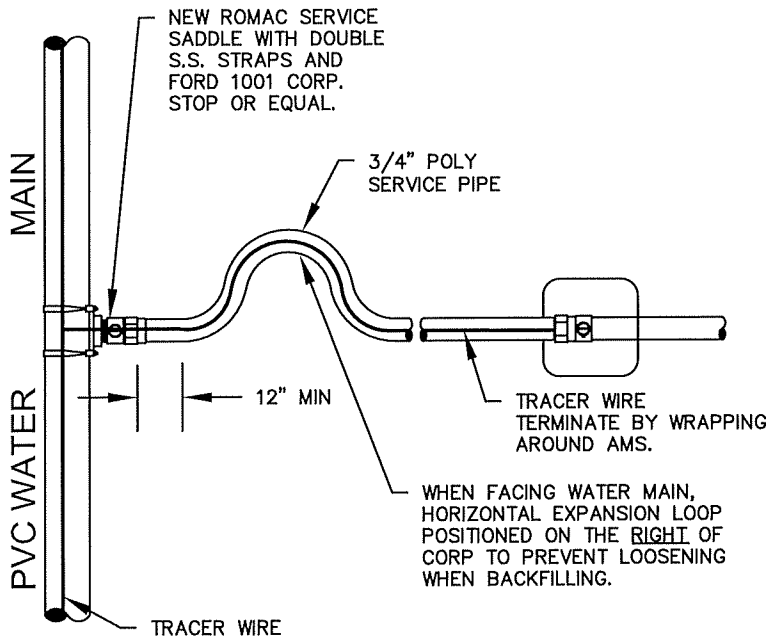

PLAN VIEW

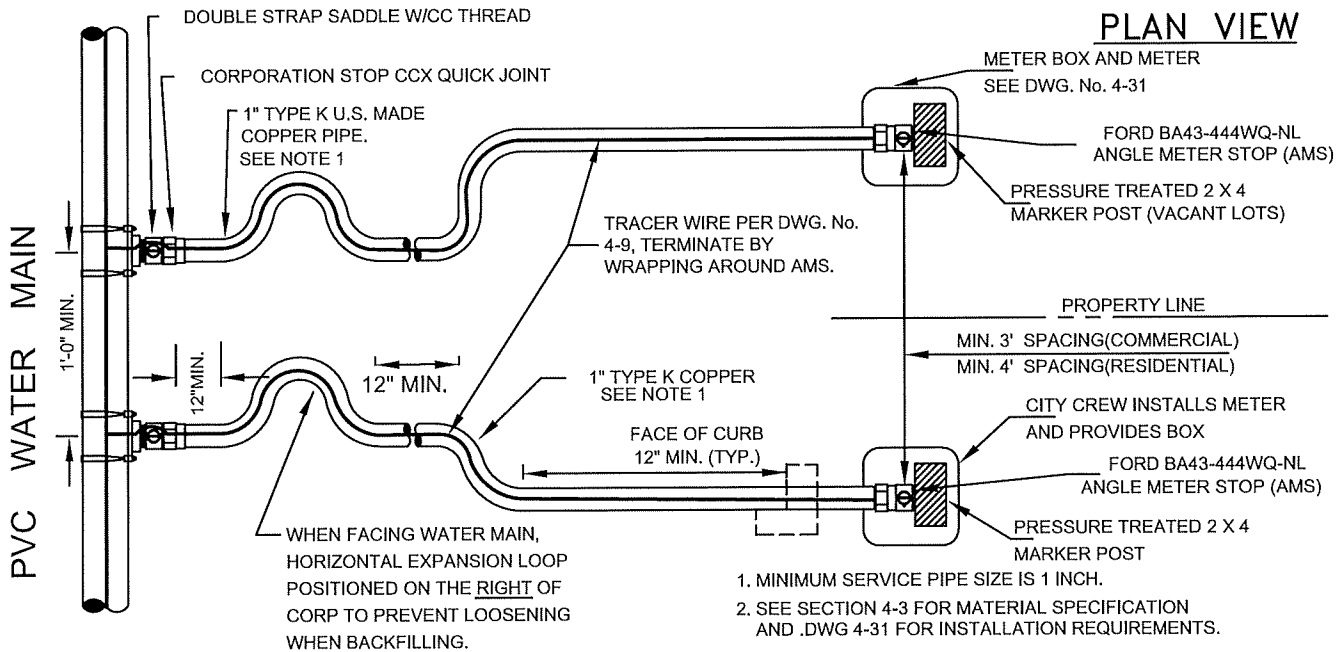

1. MINIMUM SERVICE PIPE SIZE IS 1 INCH.
2. SEE SECTION 4-3 FOR MATERIAL SPECIFICATION AND .DWG 4-31 FOR INSTALLATION REQUIREMENTS.
3. ALL BENDS TO BE A MINIMUM OF ONE FOOT FROM ALL SERVICE LINE FITTINGS.

NOTE:

ONLY THE LATEST DETAIL, AS APPROVED BY THE DIRECTOR OF PUBLIC WORKS, SHALL BE USED.

ORIG.	3/17				
REV.	DATE				DESCRIPTION

CITY OF GRANGER—STD. DETAIL

WATER SERVICE PLAN VIEW

DWG #

W7

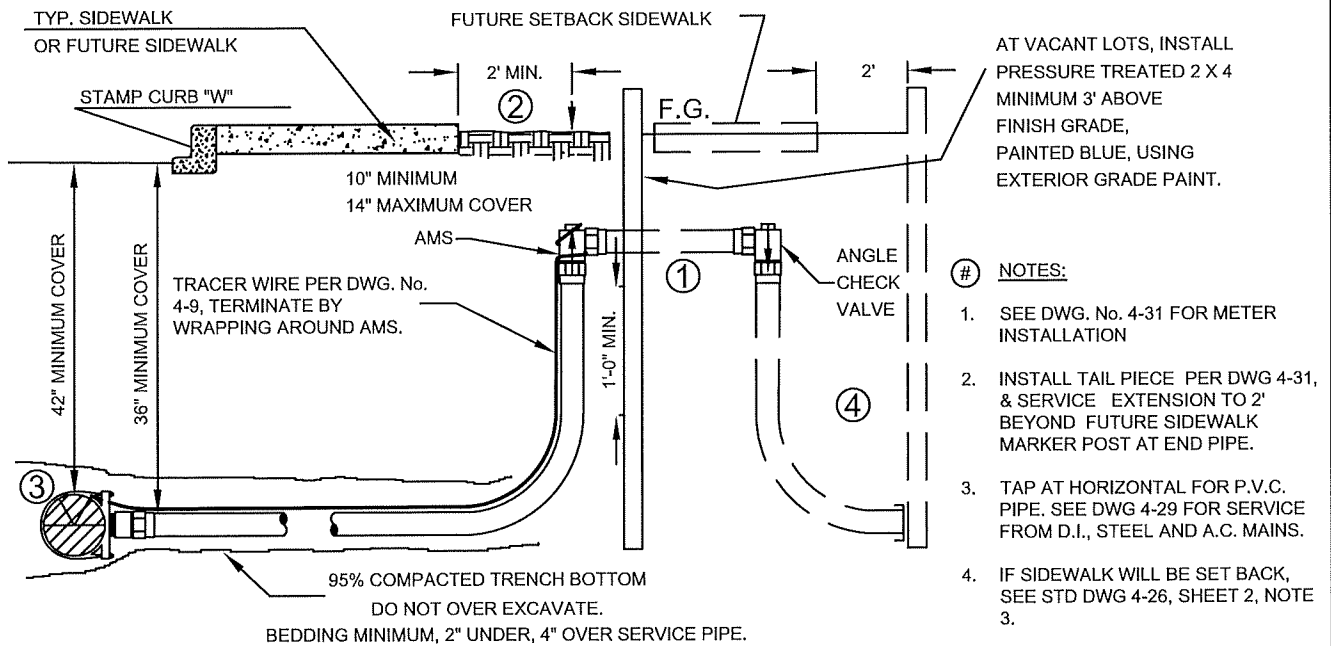
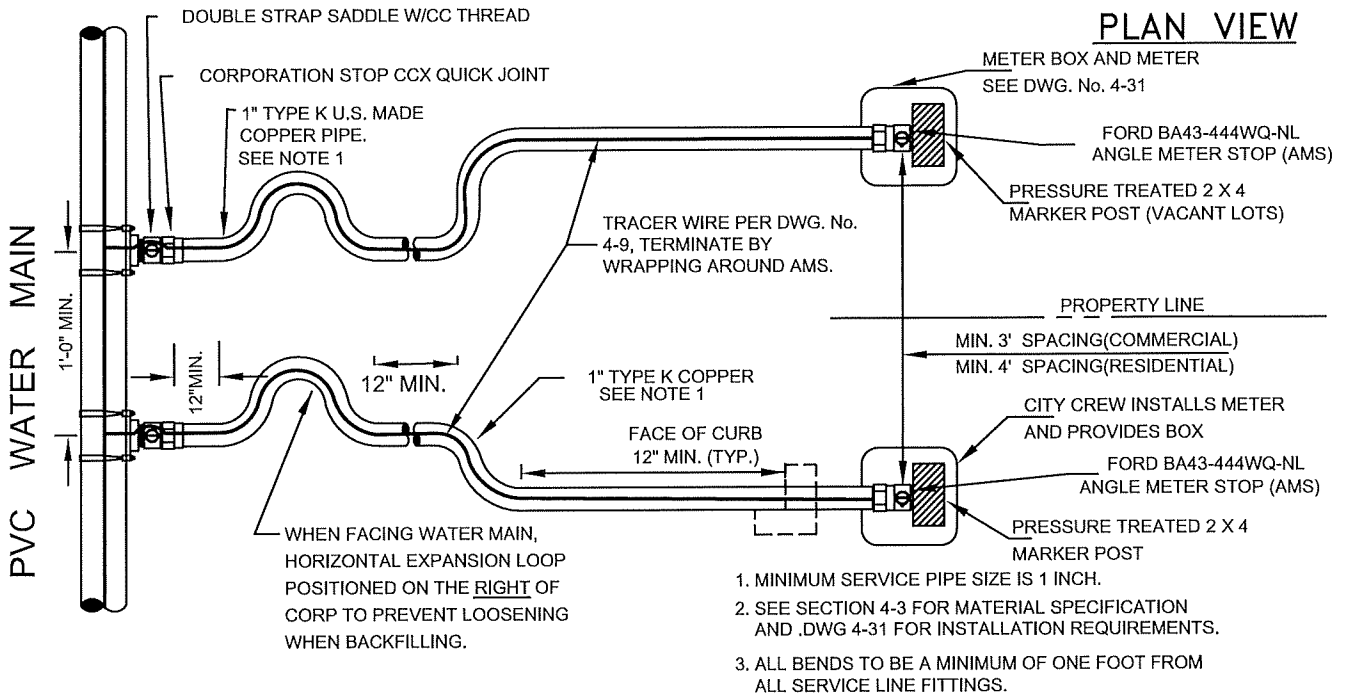

NOTE:

ONLY THE LATEST DETAIL, AS APPROVED BY THE DIRECTOR OF PUBLIC WORKS, SHALL BE USED.

REV.	DATE	DESCRIPTION
ORIG.	3/17	-

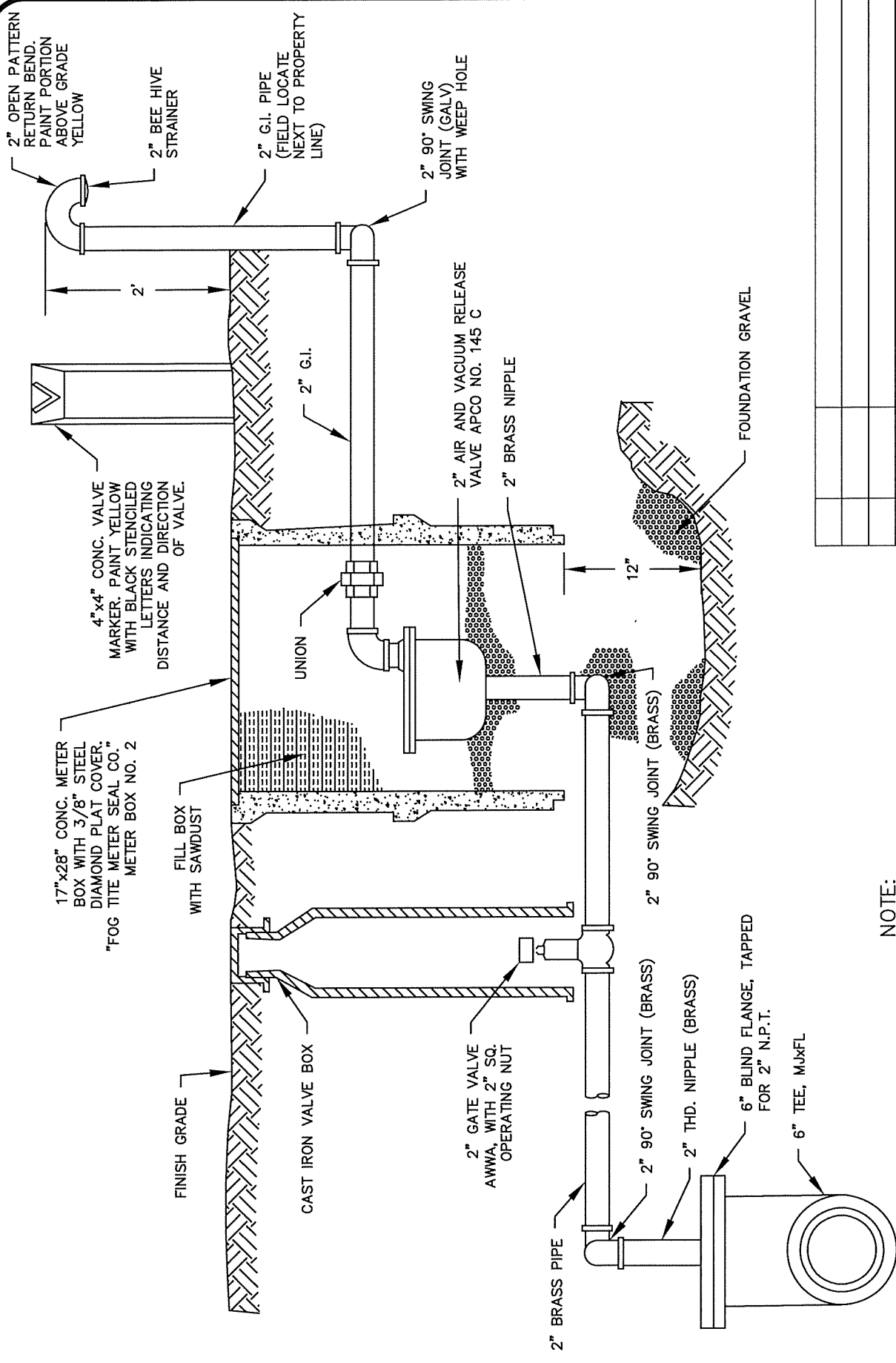

NOTE:

ONLY THE LATEST DETAIL, AS APPROVED BY THE DIRECTOR OF PUBLIC WORKS, SHALL BE USED.

REV.	DATE	DESCRIPTION
ORIG.	3/17	-

CITY OF GRANGER—STD. DETAIL

AIR/VACUUM RELEASE ASSEMBLY

DWG # **W10**

COVER TO BE MARKED "WATER"

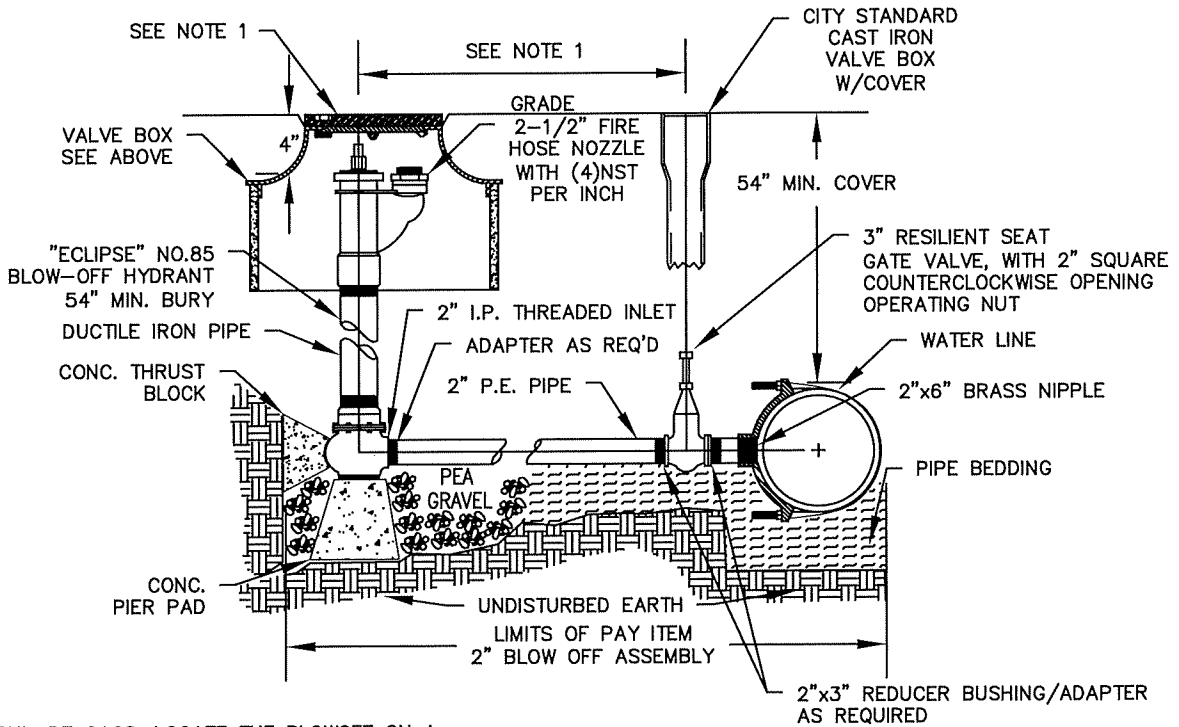
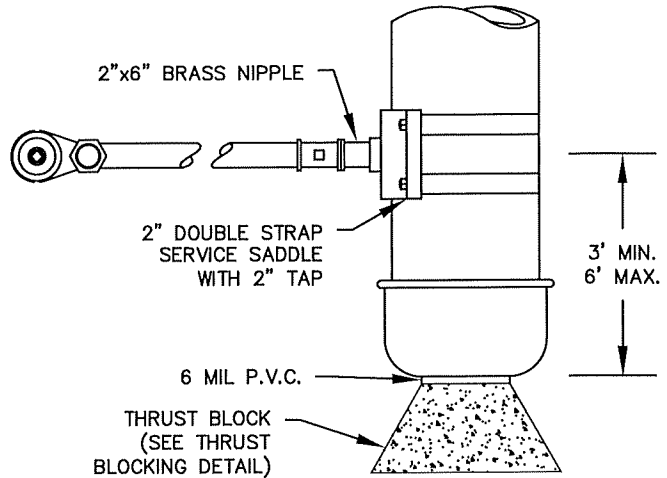
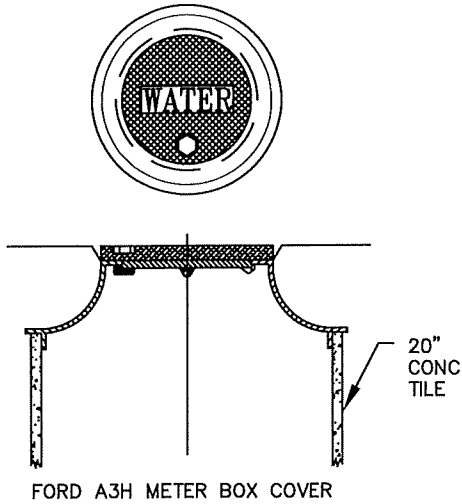

NOTE:

1. IN CUL-DE SACS, LOCATE THE BLOWOFF ON A PROPERTY LINE, CENTERED AT 1-1/2 FEET BACK OF SIDEWALK. PROVIDE ADJUSTMENT, OR CONCRETE PAD AS REQUIRED BY STANDARD DRAWING SS6. ON STANDARD STREETS, THE BLOWOFF IS TO BE LOCATED AT THE BACK OF EXISTING, OR FUTURE SIDEWALK. AT ALL INSTALLATIONS, WHEN A LANDSCAPE STRIP SEPARATES THE CURB AND WALK, LOCATE BLOWOFF 2 FEET FROM FACE OF CURB.
2. FOR WATER MAINS THAT WILL BE EXTENDED, SEE STD. DWG. W11.

NOTE:

ONLY THE LATEST DETAIL, AS APPROVED BY THE DIRECTOR OF PUBLIC WORKS, SHALL BE USED.

REV.	DATE	DESCRIPTION
ORIG.	3/17	-

CITY OF GRANGER-STD. DETAIL

2" BLOW-OFF ASSMEBLY

DWG #

W12

RESTRAINED PIPE LENGTH (FEET)

TEE BRANCH AND LENGTH EACH SIDE OF BEND

PIPE DIAMETER	TYPE OF FITTINGS												
	TEE BRANCH		90° BEND		45° BEND		22 1/2° BEND		11 1/4° BEND		DEAD END VALVE OR PLUG, AND FIRE HYDRANTS		
STATIC TEST PRESSURE (P S I)	150	200	150	200	150	200	150	200	150	200	150	200	
6 INCH	PVC	60	84	27	36	11	15	5	7	3	4	65	87
	D.I.P.	46	63	23	31	10	13	5	6	2	3	49	65
8 INCH	PVC	81	110	34	46	14	19	7	9	3	5	84	112
	D.I.P.	61	82	30	40	12	17	6	8	3	4	63	84
12 INCH	PVC	118	158	48	64	20	26	10	13	5	6	120	159
	D.I.P.	88	118	42	56	18	23	8	11	4	6	90	119
16 INCH	DUCTILE IRON	113	152	54	71	22	30	11	14	5	2	THRUST BLOCK	THRUST BLOCK
20 INCH	DUCTILE IRON	137	184	64	85	26	35	13	17	6	8		
24 INCH	DUCTILE IRON	161	216	74	98	30	41	15	20	7	10		
30 INCH	DUCTILE IRON	149	260	87	116	36	48	17	23	9	12		
36 INCH	DUCTILE IRON	223	300	100	132	41	55	20	26	10	13		

CALCULATIONS ARE BASED ON INSTALLATION IN POORLY GRADED SANDS, GRAVEL AND GRAVEL -SAND MIXTURES (GM & SM), TYPE 3 TRENCH - PIPE BEDDED IN SELECT NATIVE, OR IMPORTED EARTH BEDDING, TO A DEPTH OF 6-INCHES OVER THE PIPE (STD. DWG. W1) A MINIMUM 3 FEET OF COMPACTED PIPE BURY AT THE TIME OF THE PRESSURE TEST AND A SAFETY FACTOR OF 1.5 : 1 TO ALLOW FOR SITE CONDITION VARIABLES

NOTES:

1. FOR DESIGN FORMULAS, CALCULATIONS AND ADDITIONAL INFORMATION, THE TABLE IS BASED ON THE RESTRAINT CALCULATIONS FOUND AT WWW.ROMAC.COM/RESTRAINT/INDEX.HTML. THE RESTRAINED PIPE LENGTH APPLIES TO CONDITIONS WHERE A CONCRETE THRUST BLOCK IS NOT USED.
2. IF POLYETHYLENE WRAPPED D.I.P. IS SPECIFIED, INDEPENDENT CALCULATIONS ARE REQUIRED. DO NOT USE THE ABOVE TABLE, WHICH IS FOR STANDARD DIP ONLY.
3. EVERY JOINT WITHIN THE DESIGNATED RESTRAINT LENGTH MUST BE RESTRAINED. IF THE REQUIRED RESTRAINT LENGTH IS SHORTER THAN A SINGLE SECTION OF PIPE BEING USED, ONLY THE FITTING CONNECTION REQUIRES RESTRAINT. THE RESTRAINT LENGTH GIVEN IN THE TABLE, IS THE REQUIRED LENGTH ON EACH SIDE OF THE BEND, OR ON THE TEE BRANCH AS APPLICABLE.
4. THRUST BLOCKS ARE REQUIRED FOR ALL CONNECTIONS TO AC PIPE AND WHEN AN AC PIPE CONNECTION IS LOCATED ANYWHERE WITHIN THE DESIGNATED RESTRAINT LENGTH.
5. THRUST BLOCKS ARE REQUIRED IF THE DESIGNATED RESTRAINT LENGTH CANNOT BE OBTAINED. SPECIAL ATTENTION NEEDS TO BE GIVEN TO DEAD END STUBS AND FIRE HYDRANT INSTALLATIONS. IF THE LENGTH OF THE FEEDER PIPE, FROM THE MAIN LINE TEE TO THE END CAP, OR HYDRANT, IS LESS THAN THE DESIGNATED DEAD END RESTRAINT LENGTH, THRUST BLOCKS ARE REQUIRED AT BOTH THE TEE AND AT THE END CAP, OR HYDRANT. WHEN THE SPECIFIED CONDITIONS ALLOW THE USE OF MECHANICAL RESTRAINTS, THE RESTRAINT LENGTH REQUIREMENTS FOR BOTH THE TEE AND THE END CAP, OR HYDRANT MUST BE MET.
6. APPROVED METHODS OF RESTRAINED PIPE SHALL BE :
 - a. FOR PVC PIPE, ROMAC GRIPRING PIPE RESTRAINER AND FOR SLIP JOINTS, SERIES 1500TD BELL RESTRAINT HARNESS, OR EQUALS.
 - b. FOR DUCTILE IRON PIPE, SERIES 1100 MEGALUG RESTRAINTS AND FOR SLIP JOINTS, SERIES 1500 RESTRAINT HARNESS THROUGH 12 INCH, OR SERIES 1700 RESTRAINT HARNESS FOR LARGER PIPE, OR EQUALS.

NOTE:

ONLY THE LATEST DETAIL, AS APPROVED BY THE DIRECTOR OF PUBLIC WORKS, SHALL BE USED.

ORIG.	3/17						-
REV.	DATE						DESCRIPTION

CITY OF GRANGER-STD. DETAIL

MECHANICAL RESTRAINT

DWG #

W 14

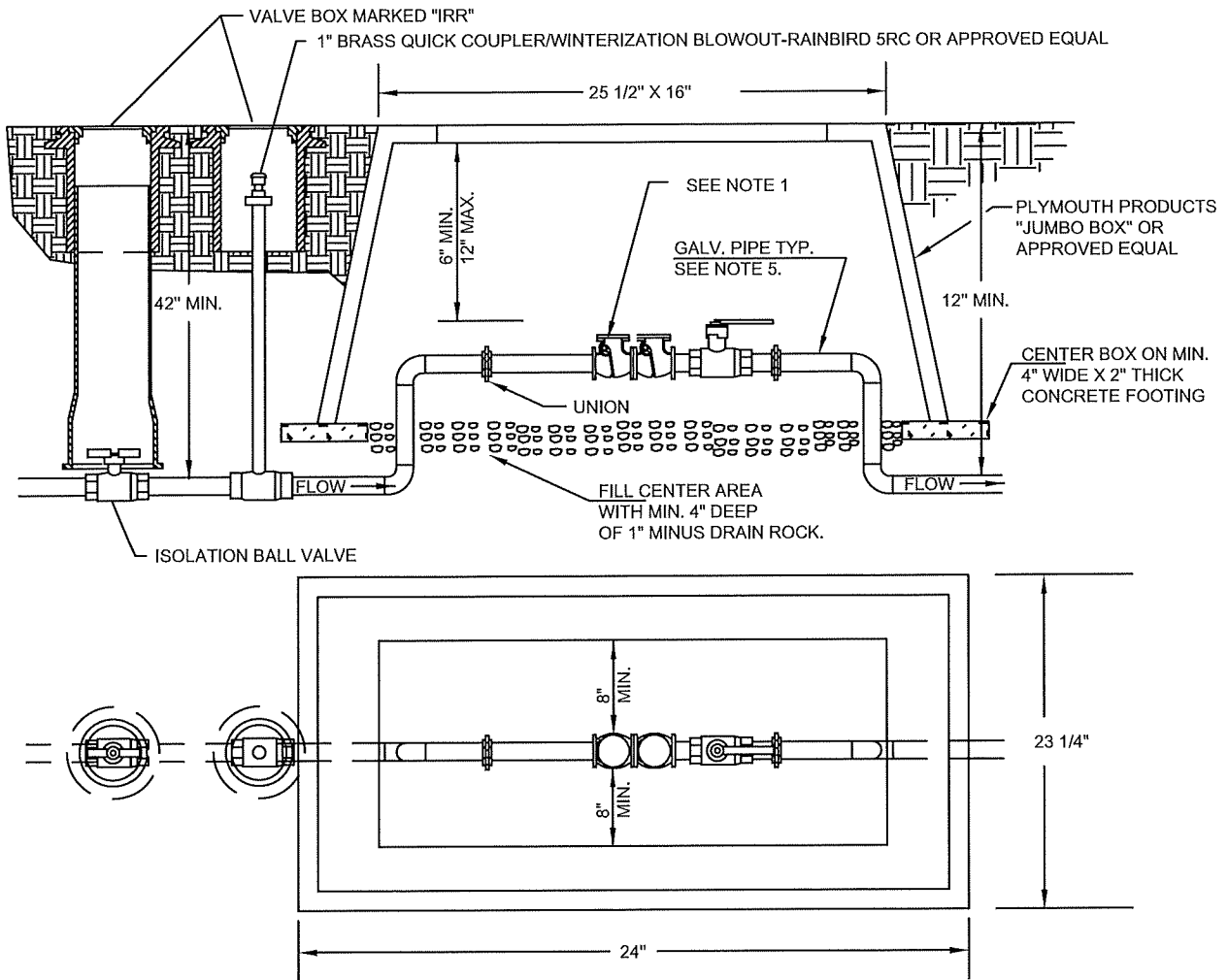

DCVA INSTALLATION

DOUBLE CHECK VALVE ASSEMBLY
FOR ASSEMBLIES 1 1/4" TO 2 1/2"

NOTES:

- 1) MUST BE ON THE LATEST DEPT. OF HEALTH APPROVED LIST OF BACKFLOW PREVENTION ASSEMBLIES.
- 2) MAY BE INSTALLED BELOW GROUND IN AN APPROVED VAULT.
- 3) A CITY OF GRANGER CROSS CONNECTION SPECIALIST MUST BE PRESENT DURING INSTALLATION.
- 4) FREEZE PROTECTION IS THE RESPONSIBILITY OF THE OWNER.
- 5) RISERS AND ALL PIPE IN BOX TO BE GALVANIZED.
- 6) A LADDER IS REQUIRED IF ACCESS OPENING TO FLOOR EXCEEDS 36"

NOTE:

ONLY THE LATEST DETAIL, AS APPROVED BY THE DIRECTOR OF PUBLIC WORKS, SHALL BE USED.

ORIG.	3/17	—
REV.	DATE	DESCRIPTION

CITY OF GRANGER—STD. DETAIL

DOUBLE CHECK VALVE ASSEMBLY

DWG #

W16

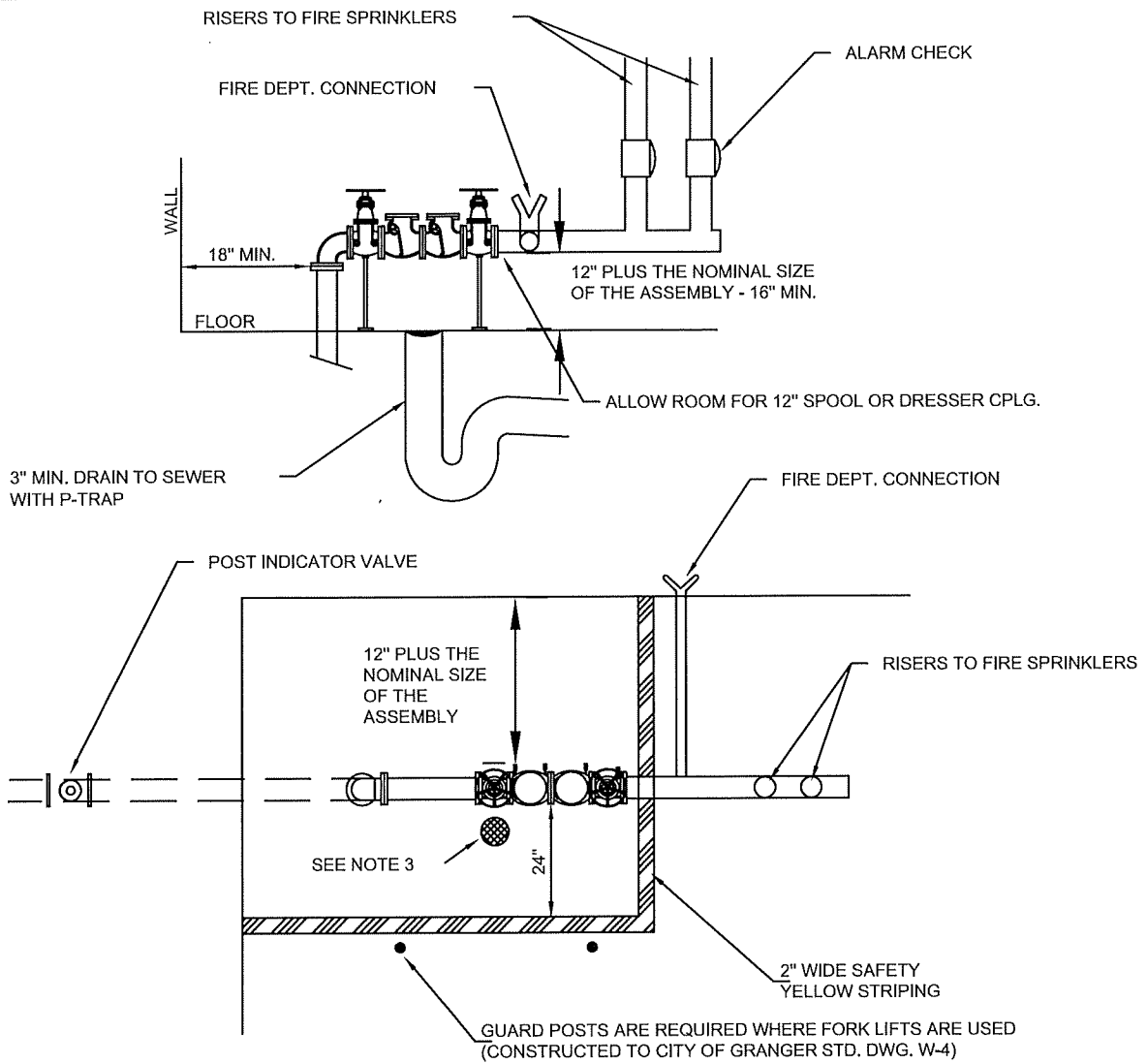

DCVA INSTALLATION

DOUBLE CHECK VALVE ASSEMBLY
FOR ASSEMBLIES 3" AND LARGER
INSTALLED INSIDE A BUILDING

NOTES:

- 1) MUST BE ON THE LATEST DEPT. OF HEALTH APPROVED LIST OF BACKFLOW PREVENTION ASSEMBLIES.
- 2) A CITY OF GRANGER CROSS CONNECTION SPECIALIST MUST BE PRESENT DURING INSTALLATION.
- 3) A MIN. 3" DIA. FLOOR DRAIN IS REQUIRED.

NOTE:

ONLY THE LATEST DETAIL, AS APPROVED BY THE DIRECTOR OF PUBLIC WORKS, SHALL BE USED.

ORIG.	3/17				
REV.	DATE				DESCRIPTION

CITY OF GRANGER—STD. DETAIL

DOUBLE CHECK VALVE ASSEMBLY

DWG #

W17

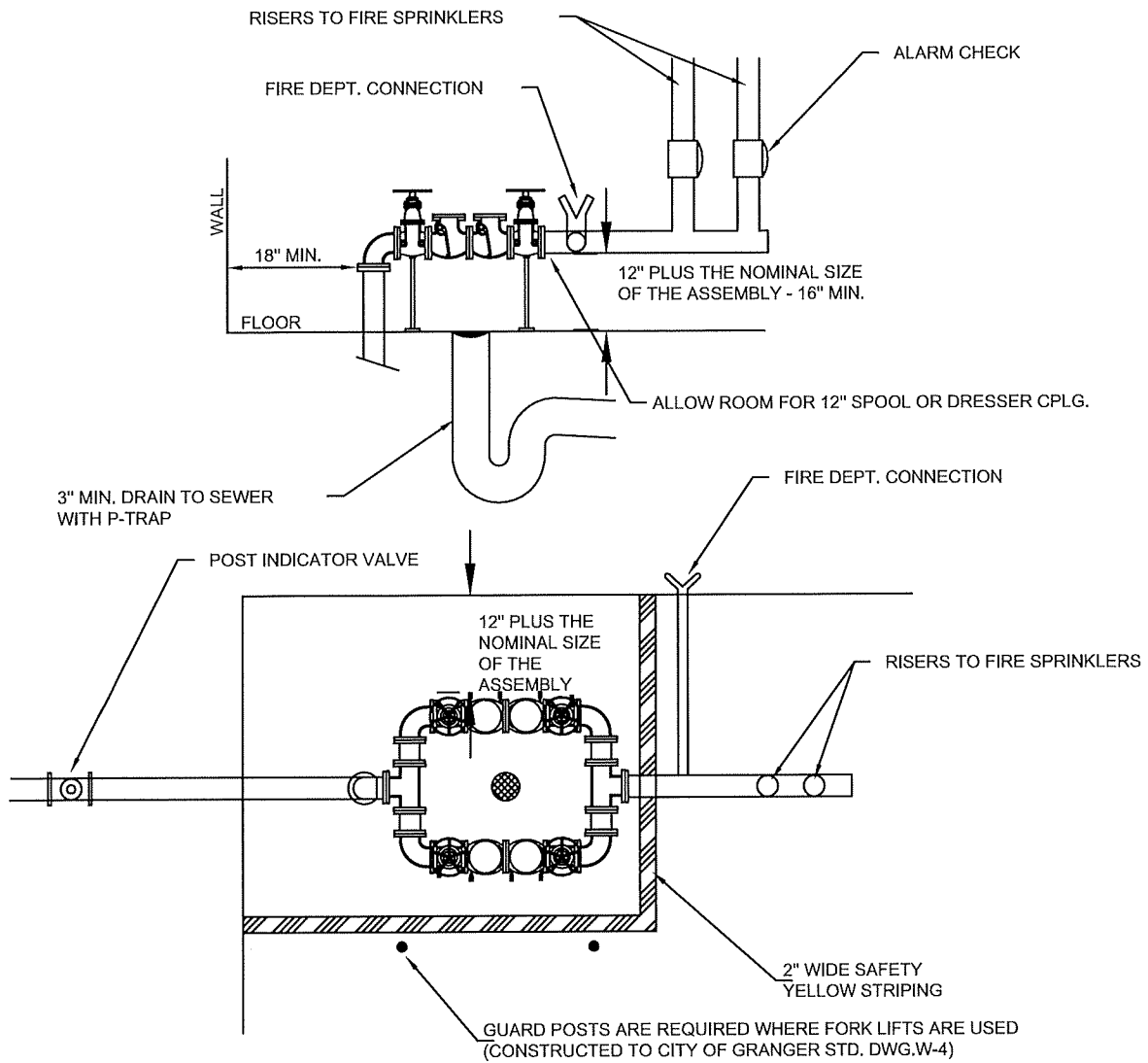

DCVA DUAL INSTALLATION

DOUBLE CHECK VALVE ASSEMBLY
FOR ASSEMBLIES 3" AND LARGER
INSTALLED INSIDE A BUILDING

NOTES:

- 1) MUST BE ON THE LATEST DEPT. OF HEALTH APPROVED LIST OF BACKFLOW PREVENTION ASSEMBLIES.
- 2) A CITY OF GRANGER CROSS CONNECTION SPECIALIST MUST BE PRESENT DURING INSTALLATION.
- 3) A MIN. 3" DIA. FLOOR DRAIN IS REQUIRED.

NOTE:

ONLY THE LATEST DETAIL, AS APPROVED BY THE DIRECTOR OF PUBLIC WORKS, SHALL BE USED.

ORIG.	3/17				
REV.	DATE				DESCRIPTION

CITY OF GRANGER—STD. DETAIL

DOUBLE CHECK VALVE ASSEMBLY

DWG #
W18

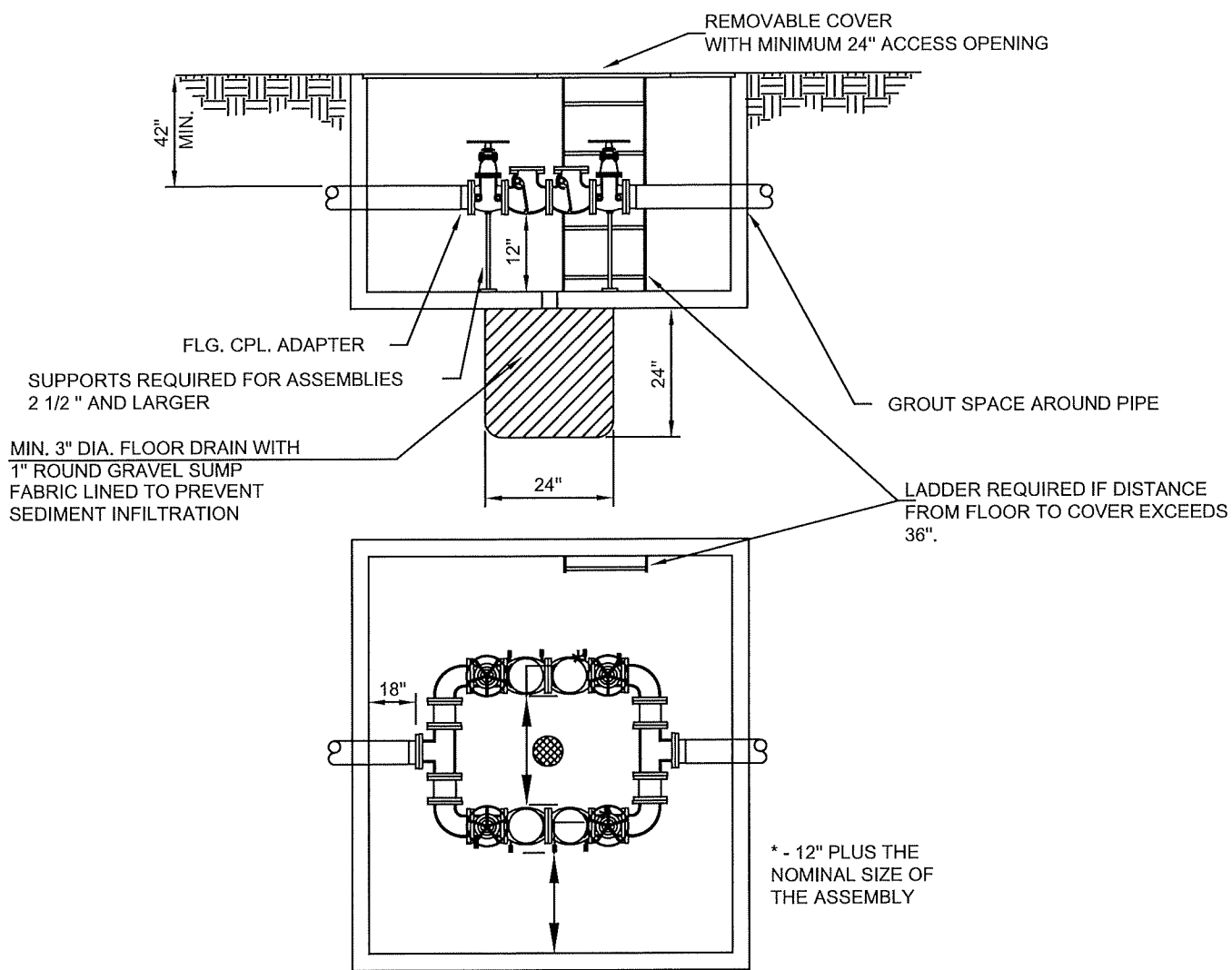

DCVA DUAL INSTALLATION

DOUBLE CHECK VALVE ASSEMBLY
FOR ASSEMBLIES 3" AND LARGER

NOTES:

- 1) MUST BE ON THE LATEST DEPT. OF HEALTH APPROVED LIST OF BACKFLOW PREVENTION ASSEMBLIES.
- 2) MAY BE INSTALLED BELOW GROUND IN AN APPROVED VAULT.
- 3) A CITY OF GRANGER CROSS CONNECTION SPECIALIST MUST BE PRESENT DURING INSTALLATION.
- 4) FREEZE PROTECTION IS THE RESPONSIBILITY OF THE OWNER.
- 5) A MIN. 3" DIA. FLOOR DRAIN IS REQUIRED.
- 6) A LADDER IS REQUIRED IF ACCESS OPENING TO FLOOR EXCEEDS 36"

NOTE:

ONLY THE LATEST DETAIL, AS APPROVED BY THE DIRECTOR OF PUBLIC WORKS, SHALL BE USED.

ORIG.	3/17	-
REV.	DATE	DESCRIPTION

CITY OF GRANGER—STD. DETAIL

DOUBLE CHECK VALVE ASSEMBLY

DWG #

W20

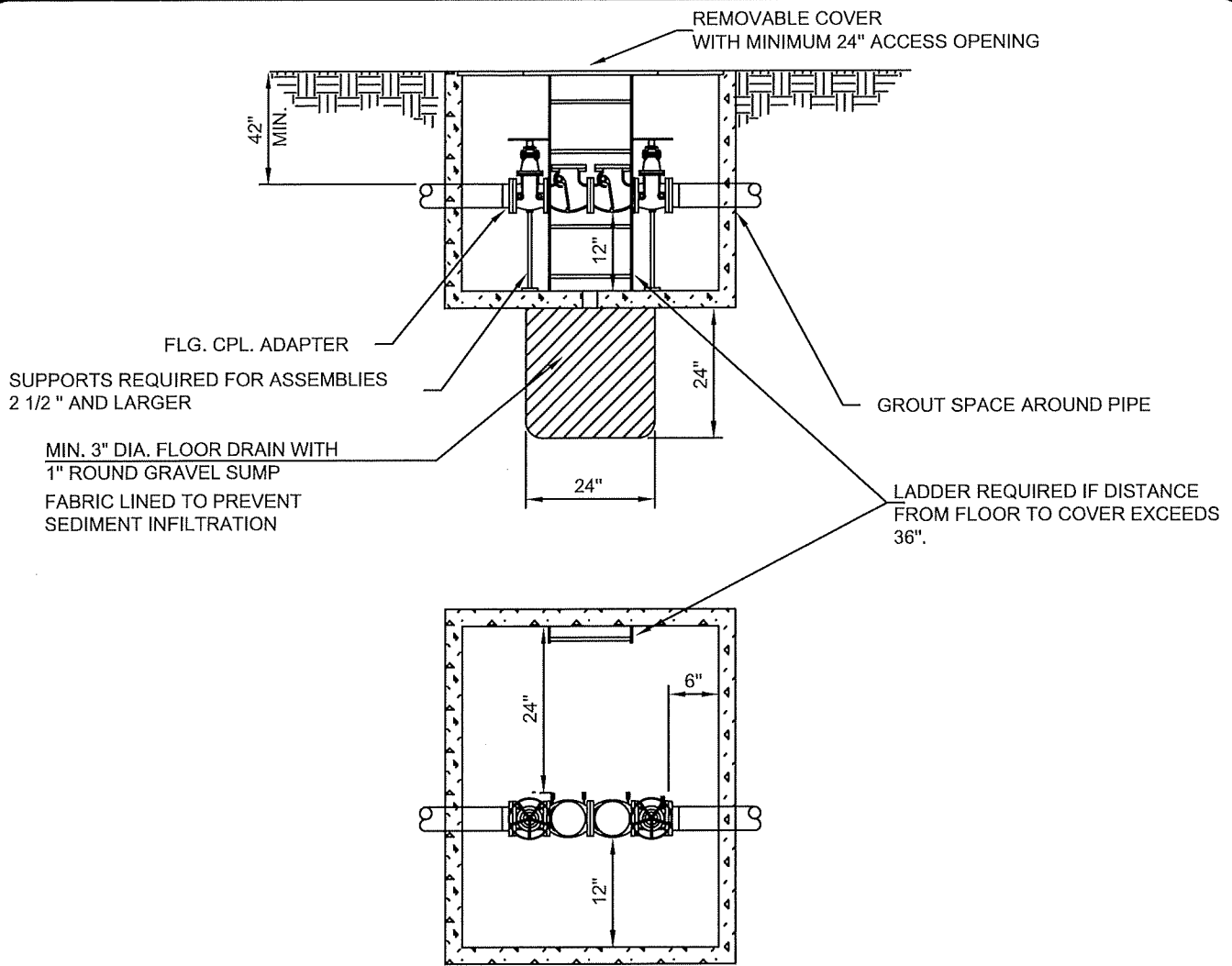

DCVA INSTALLATION

DOUBLE CHECK VALVE ASSEMBLY
FOR ASSEMBLIES 3" AND LARGER

NOTES:

- 1) MUST BE ON THE LATEST DEPT. OF HEALTH APPROVED LIST OF BACKFLOW PREVENTION ASSEMBLIES.
- 2) MAY BE INSTALLED BELOW GROUND IN AN APPROVED VAULT.
- 3) A CITY OF GRANGER CROSS CONNECTION SPECIALIST MUST BE PRESENT DURING INSTALLATION
- 4) FREEZE PROTECTION IS THE RESPONSIBILITY OF THE OWNER.
- 5) A MIN. 3" DIA. FLOOR DRAIN IS REQUIRED.
- 6) A LADDER IS REQUIRED IF ACCESS OPENING TO FLOOR EXCEEDS 36"

NOTE:

ONLY THE LATEST DETAIL, AS APPROVED BY THE DIRECTOR OF PUBLIC WORKS, SHALL BE USED.

ORIG.	3/17	-
REV.	DATE	DESCRIPTION

CITY OF GRANGER—STD. DETAIL

DOUBLE CHECK VALVE ASSEMBLY

DWG #

W21

CHAPTER 5 - SANITARY SEWER SYSTEM IMPROVEMENTS

GENERAL REQUIREMENTS FOR SANITARY SEWER SYSTEM IMPROVEMENTS

All extensions and additions to the City's sanitary sewer system shall conform to the Design and Construction Standards of the City of Granger, the Washington State Department of Ecology, and be designed by a licensed Professional Engineer as follows:

All new lots and developments shall be served by a public sanitary sewer line adjacent to the lot or development site.

Sewer lines shall be extended by the Developer to the point where the adjoining property owner's responsibility for further extension begins. This typically requires an extension across the entire frontage of the property to the property line of the adjoining owner. In some cases, it will require dedication of an easement and a line extension across the property or extension across two or more sides of the developing property.

Sewer lines shall be located in streets to serve abutting properties. When necessary, sewer lines may be located within public easements. Lines located in streets will be offset from the street centerline and not located within a vehicle wheel path. Sewer lines located in easements shall generally be located in the center of the easement, but may, with the approval of the Public Works Director, be offset to accommodate the installation of other utilities or to satisfy special circumstances.

The minimum size for public sewer lines is eight (8) inches in diameter. The developer's sewer system must provide capacity for the proposed development, but must also provide capacity for future extensions.

Sewer lines shall be terminated with a manhole. In special circumstances, a flush-end (cleanout) may be installed on the end of a sewer main extension, provided the end is no further than 150 feet from the last manhole and the sewer main line and grade will permit further extension.

Manholes shall be installed at intervals of no greater than 400 feet and at all vertical and horizontal angle points in the sewer main.

Each building containing sanitary sewer facilities shall be served by a separate private side sewer line. Branched side sewers serving multiple buildings and properties shall not be permitted. Side sewers serving multi-unit buildings are permitted.

Side sewers shall be installed in accordance with the Uniform Plumbing Code (UPC) and subject to review and approval by the City of Granger Building Inspector. Water and sewer lines shall not be laid in the same trench, except as provided in Section 1008 of the UPC and with written approval of the City of Granger Building Inspector.

Sewer lines shall be designed for gravity flow operation. Lift stations and force mains shall be limited to those locations where they are the only viable solution to serve the proposed development and other properties in the vicinity. Lift stations and force mains shall be designed by a Professional Civil Engineer licensed in the State of Washington in accordance with the direction and requirements given by the City Engineer.

The design of sewer lines and appurtenances is subject to review and approval by the City of Granger Public Works Director. The Public Works Director may, at his discretion, adjust these Design and Construction Standards as necessary to facilitate installation of sewer lines and appurtenances for the health, safety, and protection of the general public.

SPECIAL PROVISIONS FOR SANITARY SEWER SYSTEM IMPROVEMENTS

The following sections of the WSDOT Standard Specifications have been amended or supplemented as described below and apply to the construction of public works sewer system improvements within the City of Granger.

7-05 MANHOLES, INLETS, CATCH BASINS, AND DRYWELLS

7 -05.2 Materials

Supplement this section with the following:

Sanitary sewer manholes shall be gasketed and constructed of 48-inch or larger diameter reinforced precast concrete manhole sections in conformance with the requirements of this Section. The base and first barrel section shall be precast monolithically with preformed channels.

Joints in the manhole sections shall be watertight and shall be a rubber ring compression joint complying with ASTM C443, a flexible, plastic gasket, or approved equal.

Manhole frames and covers shall be cast iron with a combined weight of not less than 400 pounds and have a clear opening of 24 inches. The frames and covers shall be the manufacturer's stock pattern capable of withstanding, with appropriate margin of safety, an H20 loading. Covers shall have a 1-inch hole only, unless otherwise noted, and the top shall be flat with a non-skid pattern and marked "SEWER." The contact surfaces of the frames and covers shall be machine finished to a common plane or have other adequate provision to prevent rocking.

7-05.3 Construction Requirements

Supplement this section with the following:

The design and construction of all manholes shall provide for a 0.10 foot vertical drop through the manhole on manholes with no line change and for a 0.20 foot vertical drop through the manhole on manholes with line change.

Manhole coupling adaptors may be precast in the manhole to accept PVC pipe, provided diameters match. No field grouting of pipe into manholes will be allowed. Pipe connections at manholes must be gasketed and must be flexible. "A-Lok" gasket system or approved equal may be used as an alternate to the manhole coupling adapter.

7-05.3(1) Adjusting Manholes and Catch Basins to Grade

Delete and replace with the following:

Manholes, valve boxes, catch basins, and similar utility appurtenances and structures shall not be adjusted until the pavement is completed, **at which time the center of each structure shall be relocated from references previously established by the Contractor.**

The asphalt concrete pavement shall be cut and removed to a neat circle, the diameter of which shall be equal to the outside diameter of frame plus one (1) feet. The frame shall be placed on cement concrete blocks or adjustment rings and brought up to the desired grade. The base materials shall be removed and Class 3000 cement concrete shall be placed within the entire volume of the excavation up to, but not to exceed, 1 and 1/2 inches below the finished pavement surface.

On the following day, a tack coat of asphalt shall be applied to the concrete, the edges of the asphalt concrete pavement, and the outer edge of the casting. HMA Cl. 3/8-Inch asphalt concrete shall then be placed and compacted with hand tampers and a patching roller.

The completed patch shall match the existing paved surface for texture, density, and uniformity of grade. The joint between the patch and the existing pavement shall then be sealed with emulsified asphalt and shall be immediately covered with dry paving sand before the tack has broken.

Utility appurtenances outside paved areas shall be adjusted to finish grade as shown on City Standard Detail SS4. The utility cover shall be cleaned of all concrete prior to acceptance.

7-08 GENERAL PIPE INSTALLATION REQUIREMENTS

7 -08.1 General

Supplement this section with the following:

All construction work shall be inspected by the City of Granger prior to backfilling. At least 48 hours notice shall be given to the City Public Works Department prior to backfilling.

The Contractor shall notify the Utility Notification Center (One Call Center) at least 48 hours prior to start of excavation so that underground utilities may be marked. Telephone number is 1-800-424-5555 or 811.

7-08.3(1)C Bedding the Pipe

Supplement this section with the following:

The imported pipe bedding and select backfill to be utilized for the trench backfill shall be crushed gravel, placed and compacted in layers as designated by the Director of Public Works. Crushed gravel shall conform to Section 9-03.9(3) Crushed Surfacing Top Course.

7 -08.3(2)B Pipe Laying – General

Supplement this section with the following:

6-inch wide magnetic detectable marking tape as detailed in the City Standard Detail SS-1 shall be installed over all sewer pipe lines. The tape shall be placed approximately three feet above the top of the pipe and shall extend its full length. The horizontal location of the tape shall vary no more than one foot from the centerline alignment of the pipe. Detectable marker tape shall meet the requirements of Section 9-15.18 of the Standard Specifications.

7-08.3(3) Backfilling

Supplement this section with the following:

Street crossing trenches and other locations, where directed, shall be backfilled for the full depth of the trench with Imported Select Backfill conforming to Section 9-03.9(3) Crushed Surfacing Base Course. The Public Works Director may require the use of Controlled Density Fill (CDF) for trench backfill in certain circumstances. The requirements for CDF are set forth in CHAPTER 7, Section 8-30 of these Special Provisions.

Mechanical compaction shall be required for all trenches. The density of the compacted materials shall be at least 95% of the maximum density as determined by ASTM D 1557 Test (Modified Proctor). The Contractor shall notify City personnel 24 hours prior to scheduling compaction tests. The Contractor shall be responsible for scheduling, conducting, and paying for all testing required.

7-17 SANITARY SEWERS

7-17.1 Description

Supplement this section with the following:

The term "sewer(s)" and "sanitary sewer(s)" shall mean the same.

7-17.2 Materials

Pipe approved for use shall be as follows:

PVC Sanitary Sewer Pipe (Gravity): Polyvinyl Chloride Pipe with flexible gasketed joints shall conform to the requirements of Section 9-05.12(1) of the Standard Specifications (ASTM D3034, DR 35 for pipe sizes up to 15 inches in diameter). When restrained pipe is required, Ford 1300 mechanical pipe restraints or equal shall be used.

PVC fittings for PVC sewer pipe such as tees, wyes, elbows, plugs, caps, etc., shall be flexible gasket joint fittings acceptable for use and connection to PVC sewer pipe.

Detectable Marker Tape: Marker tape shall be a detectable type and shall be marked "SEWER," and shall conform to Section 9-15.18 of the Standard Specifications.

7-17.3 Construction Requirements

7-17.3(2)H Television Inspection

Delete the first paragraph and replace it with the following:

All new sewer lines shall be inspected by the City by use of television (TV) camera before final acceptance. The City will provide TV inspection service at Developer's expense.

7-18 SIDE SEWERS

7-18.3 Construction Requirements

7-18.3(1) General

Supplement this section with the following:

Side sewers shall be constructed with a minimum of 30 inches of cover. This provision may be waived by the Public Works Director under special circumstances; however, under no circumstances shall the side sewer be laid with less than 18 inches of cover.

Side sewers shall be a minimum of four (4) inches in diameter. Larger sizes, if required, will be approved by the Public Works Director on a case-by-case basis.

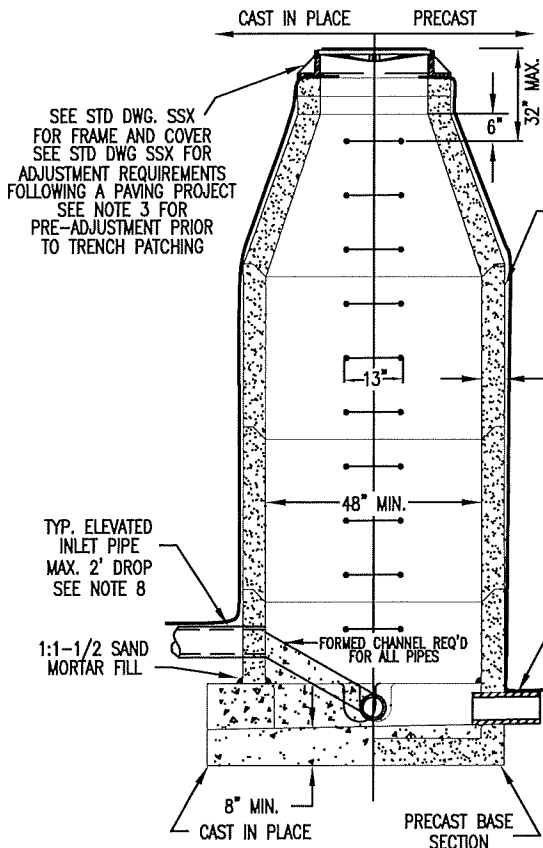

SECTION A-A

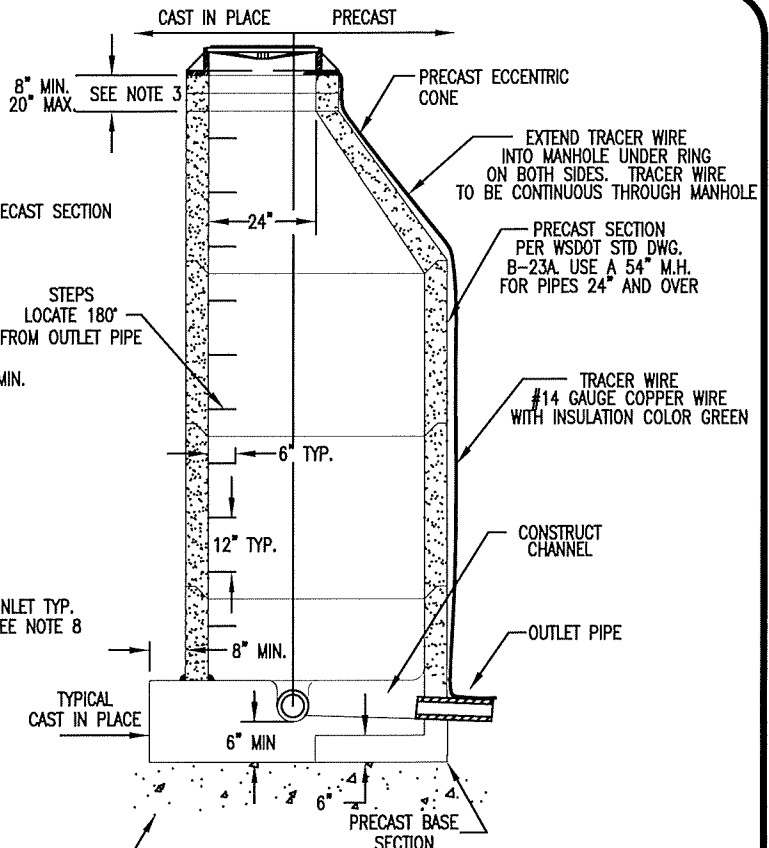

SECTION B-B

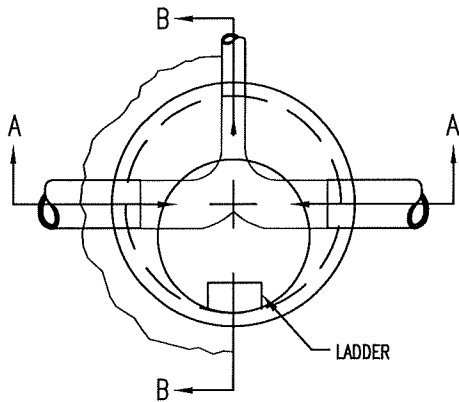

NOTE:

1. A RUBBER RING ENTRY COUPLING SHALL BE USED WITH P.V.C. PIPE.
2. ALL MANHOLE JOINTS SHALL BE MADE USING A CONTINUOUS FLEXIBLE RUBBER MANHOLE GASKET, OR FULL BED GROUT JOINT.
3. ADJUSTMENTS OVER 2" UTILIZE PRECAST CONCRETE RINGS. GROUT OR PLACE SEALANT (SONNEBORN - SONOLASTIC NPI, OR EQUAL) BETWEEN EACH RING AND AT FRAME. REMOVE ALL WOOD SHIMS AND FINISH GROUT (WIPE) INSIDE OF ADJUSTMENT RING.
4. ALL CHANNELIZATION OF MANHOLE BASES SHALL BE COVERED BY A RIGID MATERIAL DURING CONSTRUCTION OF ROAD SURFACES TO PREVENT FOREIGN MATERIALS FROM ENTERING SYSTEM PER SECTION 2-27 OF THESE SPECIFICATIONS.
5. PRIOR TO FLUSHING THE SEWER MAIN, INSTALL A SRECO, UEMSI OR EQUAL METAL STOVE PIPE WITH A 90° BEND SANDTRAP, THE SAME DIAMETER AS THE SEWER MAIN, IN THE DOWN STREAM INVERT OF THE NEXT MANHOLE.
6. WHEN CONSTRUCTING MANHOLE OVER AN EXISTING MAIN, SUPPORT PIPE(S) WITH CONCRETE BLOCK AND POUR BASE AS SHOWN. REMOVE TOP 1/2 OF MAIN PIPE AND FORM SIDE CHANNEL(S) AS REQUIRED.
7. PROVIDE A MINIMUM 0.1 FOOT IN-OUT DROP FOR STRAIGHT RUNS AND 0.2 FOOT IN-OUT DROP FOR ANGLE RUNS.
8. WHEN CONNECTING TO AN EXISTING MANHOLE, PIPE HOLE TO BE SAW CUT.
9. BACKFILL AROUND MANHOLE SHALL BE ENTIRELY CRUSHED SURFACING TOP COURSE WHEN MANHOLE IS UNDER OR WILL BE UNDER PAVEMENT.

MINIMUM 5' INVERT TO COVER. SEE SHEET 2 FOR SHALLOW MANHOLES

NOTE:

ONLY THE LATEST DETAIL, AS APPROVED BY THE DIRECTOR OF PUBLIC WORKS, SHALL BE USED.

ORIG.	3/17	
REV.	DATE	DESCRIPTION

CITY OF GRANGER-STD. DETAIL

TYPICAL MANHOLE DETAIL

DWG #

SS2

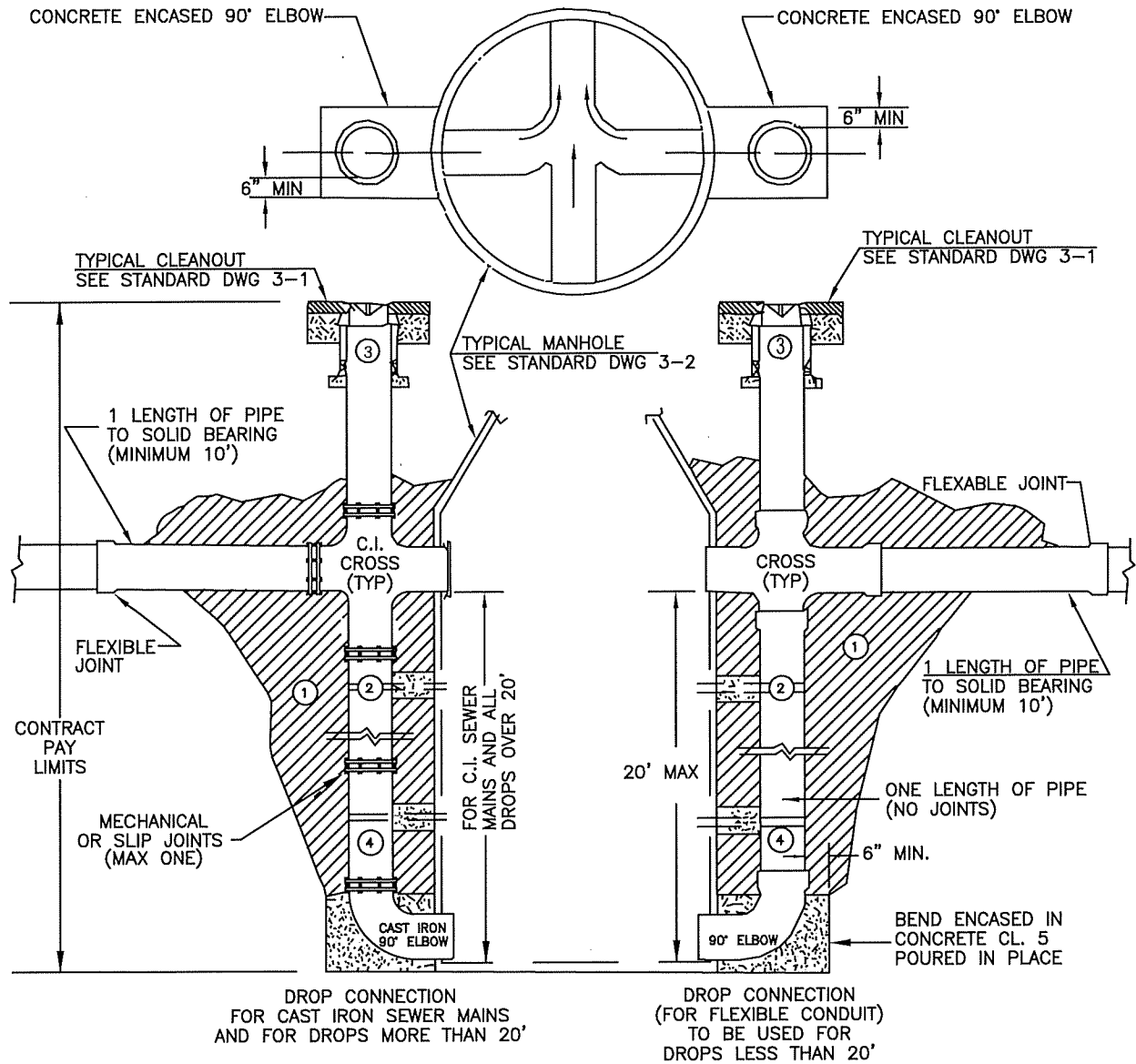

NOTES:

1. BACKFILL AROUND MANHOLE AND PIPES SHALL BE ENTIRELY CRUSHED SURFACING TOP COURSE WHEN MANHOLE IS UNDER OR WILL BE UNDER PAVEMENT OR SELECT NATIVE BACKFILL MATERIAL IMPORTED BACKFILL MATERIAL COMPACTED PER SPECIFICATIONS
2. STAINLESS BANDS WITH CONCRETE SPACER TO MANHOLE (5' MAX. SPACING, 1' MIN.)
3. SEE STD DWG 3-1 FOR CLEANOUT DETAILS (NOT SHOWN)
4. DROP CONNECTION PIPE DIAMETER AND FITTINGS SHALL BE EQUAL TO OR GREATER THAN THE DIAMETER OF THE SEWER MAIN.

NOTE:

ONLY THE LATEST DETAIL, AS APPROVED BY THE DIRECTOR OF PUBLIC WORKS, SHALL BE USED.

ORIG.	3/17	
REV.	DATE	DESCRIPTION

CITY OF GRANGER—STD. DETAIL

EXTERIOR DROP
MANHOLE CONNECTION

DWG #
SS6

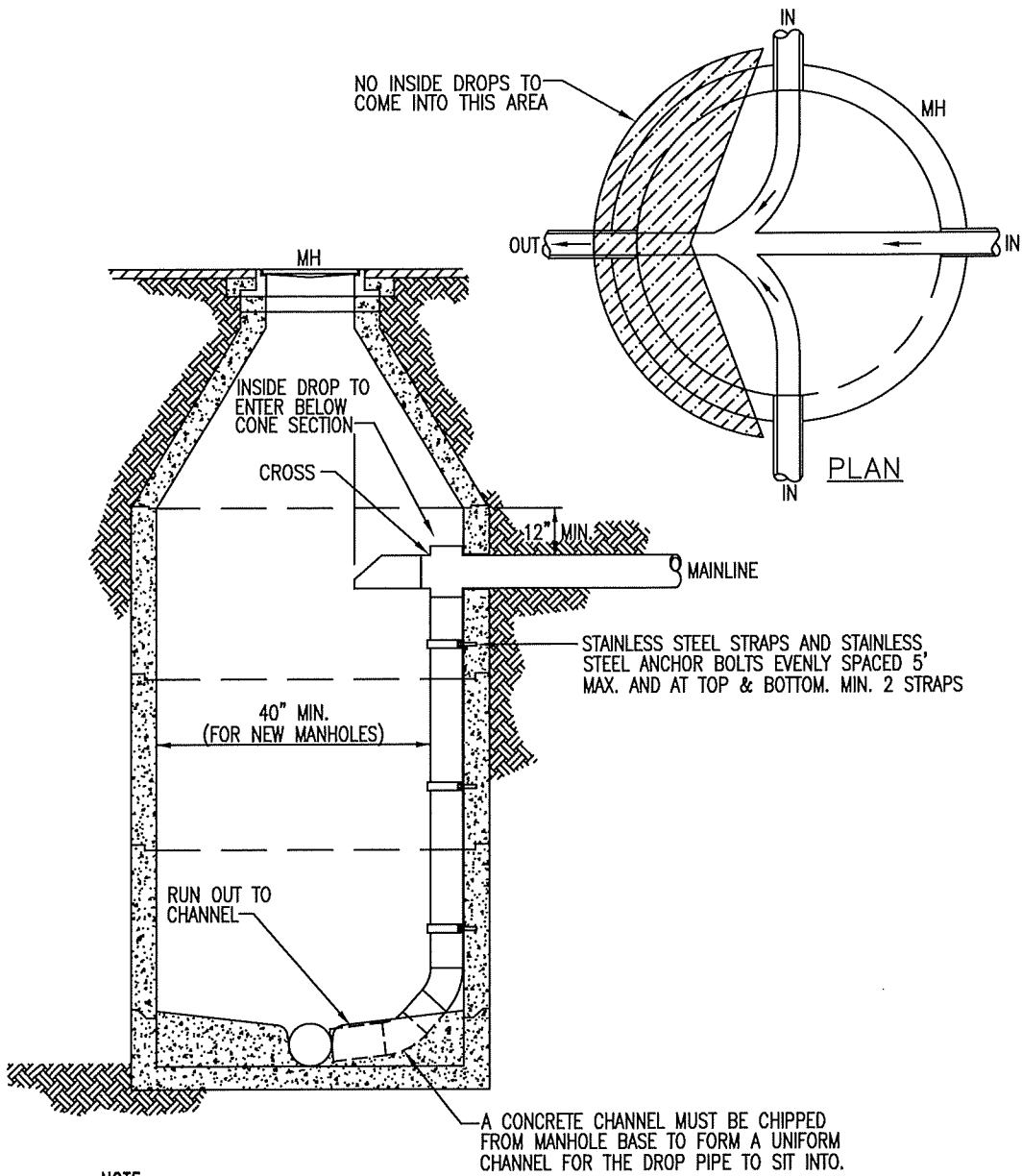

NOTE:

1. DROP CONNECTION PIPE DIAMETER AND FITTINGS SHALL BE EQUAL TO OR GREATER THAN THE DIAMETER OF THE SEWER SERVICE.

NOTE:

ONLY THE LATEST DETAIL, AS APPROVED BY THE DIRECTOR OF PUBLIC WORKS, SHALL BE USED.

ORIG.	3/17	-
REV.	DATE	DESCRIPTION

CITY OF GRANGER—STD. DETAIL

INTERIOR DROP
MANHOLE CONNECTION

DWG #

SS7

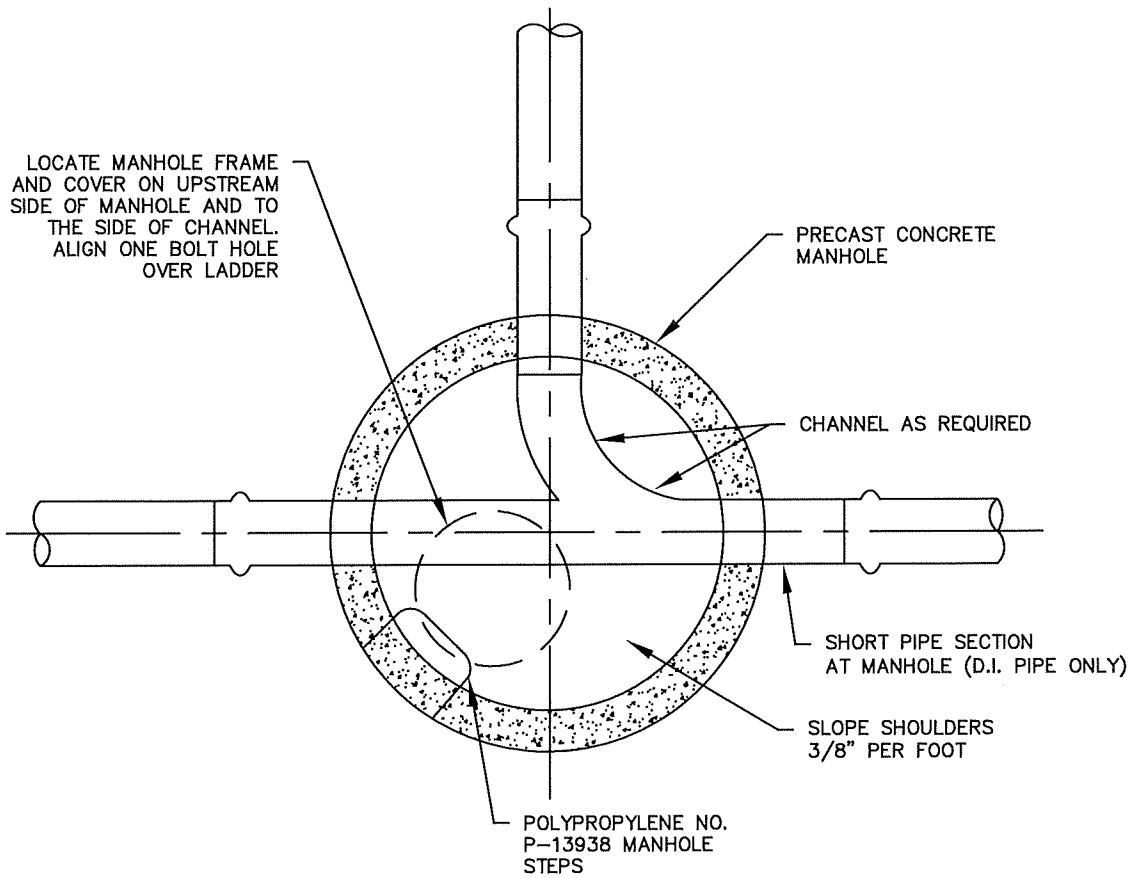

NOTE:

PIPE CONNECTIONS TO MANHOLES SHALL BE AS FOLLOWS:
 PVC PIPE: CORE THE MANHOLE AND CONNECT SEWER PIPE WITH A WATER TIGHT FLEXIBLE RUBBER BOOT IN MANHOLE WALL, KOR-N-SEAL BOOT, "A" LOCK, OR EQUAL.
 D.I. PIPE: BELL AND SPIGOT JOINT OR FLEXIBLE COUPLING. EITHER SHALL BE 12" MAXIMUM DISTANCE FROM MANHOLE WALL.
 ALL CONNECTIONS TO EXISTING MANHOLES SHALL BE MADE WITH A CONCRETE CORING MACHINE.

NOTE:

ONLY THE LATEST DETAIL, AS APPROVED BY THE DIRECTOR OF PUBLIC WORKS, SHALL BE USED.

ORIG.	3/17	-
REV.	DATE	DESCRIPTION

CITY OF GRANGER—STD. DETAIL

TYPICAL MANHOLE PLAN

DWG #

SS8

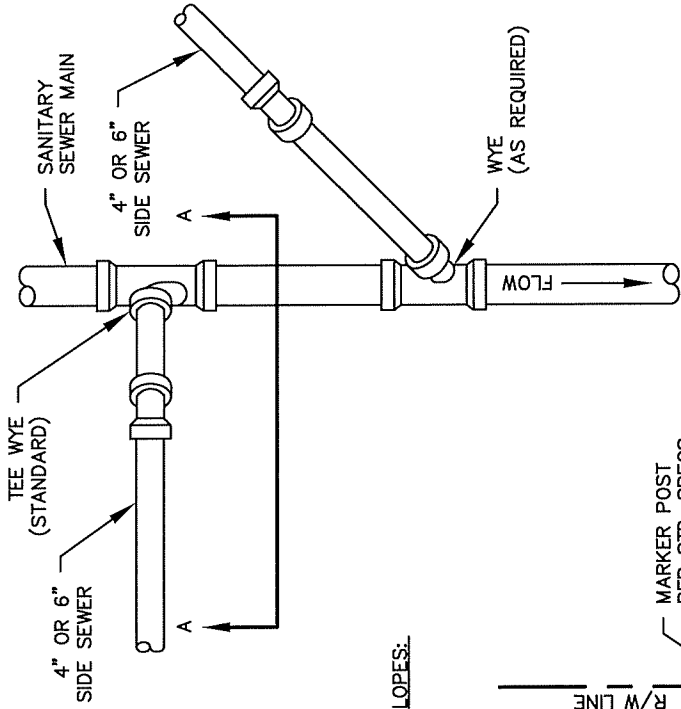

MINIMUM SIDE SEWER SLOPES:
 4" PIPE = 0.02 FT/FT
 6" PIPE = 0.01 FT/FT

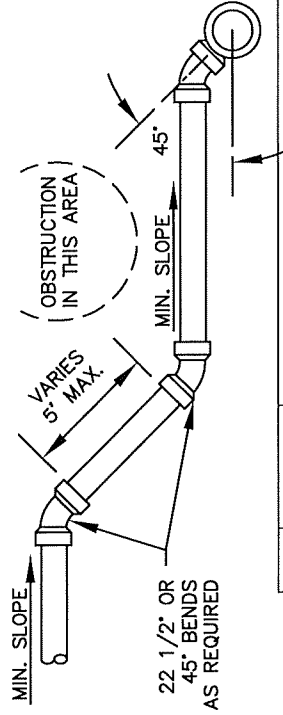
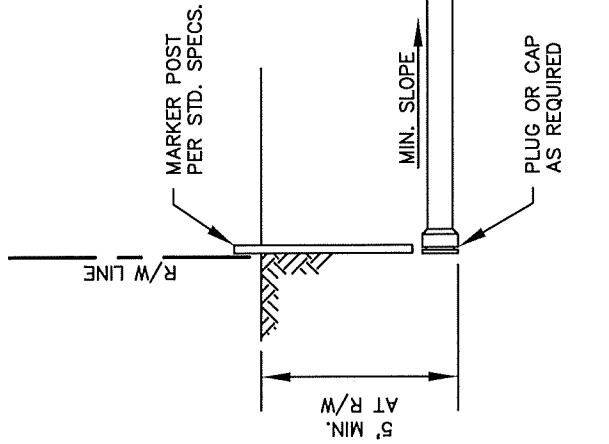

- NOTES:**
1. SERVICE CONNECTIONS 8" OR LARGER MUST BE MADE AT MANHOLE.
 2. IF 5' MAXIMUM SLOPED DISTANCE IS INSUFFICIENT FOR SIDE SEWER CONNECTION, INSTALL SIDE SEWER RISER PER DETAIL.
 3. ROTATE SANITARY SEWER MAIN TEE WYE OR WYE 45° UPWARD.
 4. TEE WYES OR WYES SHALL BE INSTALLED IN NEW SANITARY SEWER MAINS. WHEN INSTALLING SIDE SEWERS IN EXISTING MAINS, CONNECTION SHALL BE MADE BY MACHINE MADE TAP AND APPROVED SADDLE.
 5. WHERE DEPTH IS INSUFFICIENT TO ALLOW CONNECTION AS SHOWN, CONNECT SERVICE AS DIRECTED BY ENGINEER OR PUBLIC WORKS DIRECTOR.
 6. TERMINATE SIDE SEWER AT R/W LINE UNLESS OTHERWISE DIRECTED BY ENGINEER OR PUBLIC WORKS DIRECTOR OR SHOWN OTHERWISE ON PLANS.
 7. ALL SIDE SEWER MATERIALS SHALL BE PVC SEWER PIPE CONFORMING TO THE REQUIREMENTS OF SECTION 9-05.12 OF THE STANDARD SPECIFICATIONS.

NOTE:

ONLY THE LATEST DETAIL, AS APPROVED BY THE DIRECTOR OF PUBLIC WORKS, SHALL BE USED.

CITY OF GRANGER-STD. DETAIL

SIDE SEWER CONNECTION

DWG #

SS10

REV.	DATE	DESCRIPTION
ORIG.	3/17	-

MIN. SLOPE
 VARIES 5° MAX.
 45°
 MIN. SLOPE
 OBSTRUCTION IN THIS AREA
 22 1/2" OR 45° BENDS AS REQUIRED

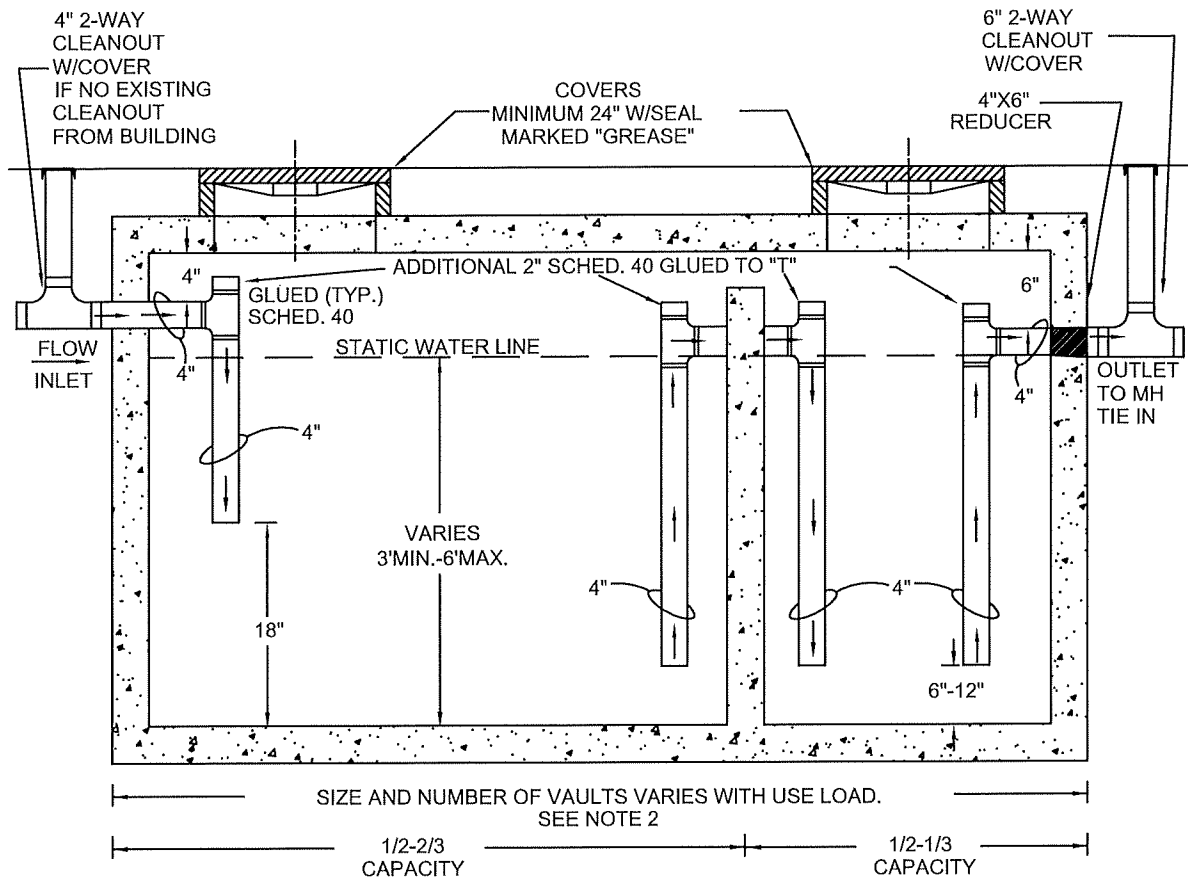

1. ALL GREASE INTERCEPTORS SHALL CONFORM TO WAC 246-272C-0230 AND CHAPTER 10 OF THE UNIFORM PLUMBING CODE AND SHALL BE DESIGNED AND INSTALLED ACCORDING TO THE LATEST PUBLICATION.
2. ALL GREASE INTERCEPTORS SHALL BE SIZED IN ACCORDANCE TO THE REQUIREMENTS AS OUTLINED IN THE UNIFORM PLUMBING CODE AND CALCULATIONS SHALL BE SUBMITTED TO THE AUTHORITY HAVING JURISDICTION FOR APPROVAL PRIOR TO INSTALLATION.
3. TRAFFIC RATED TANKS REQUIRED WHEN LOCATED IN TRAFFIC AREAS.
4. GREASE INTERCEPTORS SHALL BE LOCATED SO AS TO BE ACCESSIBLE FOR CLEANING AND INSPECTION.
5. TANK LENGTH SHALL BE GREATER THAN TANK WIDTH.
6. INSTALLATION OF GREASE TRAPS IN DRIVE THRU AND PARKING STALLS PROHIBITED.
7. NO SEWAGE, DISH WASHERS, OR GARBAGE DISPOSALS SHALL BE CONNECTED TO GREASE INTERCEPTORS.
8. ANY VARIANCE FROM THIS DETAIL MUST HAVE PRIOR APPROVAL FROM THE AUTHORITY HAVING JURISDICTION.

NOTE:

ONLY THE LATEST DETAIL, AS APPROVED BY THE DIRECTOR OF PUBLIC WORKS, SHALL BE USED.

ORIG.	3/17	-
REV.	DATE	DESCRIPTION

CITY OF GRANGER—STD. DETAIL

GREASE INTERCEPTOR

DWG #

SS11

CHAPTER 6 - STORMWATER IMPROVEMENTS

GENERAL REQUIREMENTS FOR STORMWATER IMPROVEMENTS

All extensions and improvements to the City of Granger's storm sewer (storm drain) system shall conform to the following design standards and requirements of the City. Private systems, where required by applicable provisions of the Granger Municipal Code, shall also comply with these requirements.

Storm runoff occurring on all new lots and developments (private property) shall be retained and disposed of on-site. No storm runoff will be allowed to enter public property or the public storm drainage system. The property owner shall maintain all stormwater BMPs that are installed on private property.

Storm runoff for new public streets shall be designed and constructed as required to the point where the adjoining property owner's responsibility for further extension begins. This typically requires an extension across the entire frontage of the property to the property line of the adjoining owner.

All storm sewer designs for new public streets shall be based upon an engineering analysis that takes into account total drainage areas, runoff rates, pipe and inlet capacities, treatment capacity, and any other factors pertinent to the design.

All new storm drainage facilities, public or private, shall be designed by a Professional Engineer licensed in the State of Washington. Complete stormwater runoff and drainage facilities sizing calculations shall be submitted to the City of Granger for review and comment.

All storm drainage improvements shall be planned, designed, permitted, constructed and maintained in accordance with the requirements of the latest edition of the Washington Department of Ecology (WDOE) *Storm water Management Manual for Eastern Washington* (SWMMEW).

All subsurface infiltration facilities used for the treatment and disposal of stormwater shall meet the requirements of and be registered with the WDOE Underground Injection Control (UIC) program. The registration process shall be completed prior to project acceptance.

Inlet spacing shall be designed in accordance with the WSDOT Hydraulics Manual, Chapter 5. Generally, inlet spacing shall not exceed 300 feet. There shall be a manhole or Type II catch basin installed at the intersection of two collector storm sewers. A collector storm sewer is a sewer servicing more than one catch basin.

DESIGN CRITERIA

The SWMMEW allows different methodologies to apply design storms to stormwater facility design. For purposes of consistency, specific design storm amounts of precipitation are provided below and summarized in Table 6-1. Precipitation amounts are taken from the figures and calculation methods provided in the SWMMEW. Once the rainfall amount is known, hydrographic methods are used to determine the rate and volume of runoff from the selected design storm, and to mathematically route a storm through proposed facilities. Hydrographic

methods are discussed below along with their application to different design conditions in Granger.

DESIGN STORMS

Design storms are used to establish the amount of precipitation to be used in calculating the runoff from a parcel or basin. Based on rainfall records and methods outlined in the SWMMEW, the storm events described below are applicable to Granger. Note that all 24-hour storm precipitation amounts have been adjusted by a factor of 1.0 for use in the long-duration storm for Eastern Washington Region 2.

Water Quality 3-Hour Storm - 0.26 inches of precipitation. This short-duration water quality storm event is intended to provide treatment for the "first flush" events and is representative of a summer thundershower. The "first flush" can be thought of as the first amount of water that enters the system during a storm, which typically contains the highest concentration of pollutants such as roadway grit, dust and oils.

Water Quality 24-Hour Storm - 0.53 inches of precipitation. This desired long-duration water quality storm event is intended to provide treatment for the "first flush" events. All stormwater treatment BMPs should be designed to treat runoff from this 24-hour water quality storm.

2-Year, 24-Hour Storm - 0.8 inches of precipitation. This long-duration storm has a two-year return frequency, or a 50 percent chance of occurring in any one year. Designing to the 2-year storm is considered necessary for control of nuisance water. The 2-year storm also has other applications for the design of stormwater detention and water quality treatment facilities.

10-Year, 24-Hour Storm - 1.3 inches of precipitation. This long-duration storm has a 10-year return frequency, or a 10 percent chance of occurring in any one year. Historically, storm drain facilities were designed to carry flows from this storm, but it was found that in Eastern Washington, stormwater facilities were better protected if they were designed to carry flows from the summer thunderstorm, which has greater rainfall intensity over a shorter period of time.

25-Year, 3-Hour Storm - 0.92 inches of precipitation. This short-duration storm has a 25-year return frequency, or a 4 percent chance of occurring in any one year. This unique storm is representative of the summer thunderstorm where a significant amount of rainfall occurs over a 3-hour period, and should be used for design of flow control facilities.

25-year, 24-Hour Storm - 1.6 inches of precipitation. This long-duration storm has a 25-year return frequency, or a 4 percent chance of occurring in any one year. Volume-based BMPs should be designed for this 24-hour, long-duration storm. The intensity of this storm is lower since the rainfall occurs more slowly over an extended time within the 24-hour period. Therefore, the runoff rate is lower, but the volume is greater than the 3-hour storm.

50-Year, 24-hour, Storm - 1.8 inches of precipitation. This long-duration storm has a 50-year return frequency, or a 2 percent chance of occurring in any one year. Minor ponding is acceptable during this event, as long as the streets remain passable, and buildings are not flooded.

100-Year, 24-Hour Storm - 2.0 inches of precipitation. This long-duration storm has a 100-year return frequency, or a 1 percent chance of occurring in any one year. Major structures and critical facilities should be protected from damage by flows from this storm.

**TABLE 6-1
PRECIPITATION EVENT INFORMATION**

Storm Event	Precipitation (Inches)
6-Month, 3-Hour Storm Event	0.26
6-Month, 24-Hour Storm Event	0.53
2-Year, 24-Hour Storm Event	0.8
10-Year, 24-Hour Storm Event	1.3
25-Year, 3-Hour Storm Event	0.92
25-Year, 24-Hour Storm Event	1.6
50-Year, 24 Hour Storm Event	1.8
100-Year, 24-Hour Storm Event	2.0
Source: <i>Stormwater Management Manual for Eastern Washington</i> , WDOE, Sep. 2004 Note: 24-hour precipitation amounts have been adjusted for use in the long-duration regional storm distribution.	

HYDROLOGIC ANALYSIS

Hydrologic analysis determines the amount of runoff from a given storm for a given drainage area. Though hydrologic studies are backed with considerable science, there is still a certain amount of art in their application. Available methods range from the simple calculations of the Rational Method to complex computer models, requiring significant data input and knowledge of hydrologic effects.

The following hydrographic methods are considered acceptable for the watersheds within Granger and its urban growth area:

- The Santa Barbara Urban Hydrograph (SBUH) method may be used for all analyses regardless of the size of the drainage area. Input parameters shall be as described by WDOE or WSDOT for the design storms described above. Other computer models may also be used with prior approval by the City.
- For drainage areas less than or equal to 20 acres, the rational formula and modified rational method, as described in older WSDOT and Soil Conservation Service publications, may be used for flow-rate-based applications. Inputs shall be as described in those publications, or other engineering texts. The SCS Unit Hydrograph Method may also be used.
- For drainage areas greater than 20 acres, and when it is necessary to route flows through detention facilities, the SCS Unit Hydrograph Method may be used. Inputs

shall be as described in WSDOT and Soil Conservation Service publications, or other engineering texts.

The SBUH method uses a hyetograph to depict the intensity (amount) of rainfall versus time. A hyetograph may also be required for routing design storms through some BMPs. Design storm hyetographs applicable to Granger stormwater facilities are as follows:

- Water Quality Volume-Based Treatment BMPs - 24-hour SCS Type 1A storm with a 6- month return frequency.
- Water Quality Flow-Rate-Based Treatment BMPs - 24-hour SCS Type II storm with a 6- month return frequency.
- Volume-Based BMPs - 24-hour SCS Type 1A Storm with a 25-year return frequency.
- Flow-Rate-Based BMPs - 3-hour short-duration storm with a 25-year return frequency as described in the SWMMEW.
- Critical facilities required to carry 50- and 100-year storms - 24-hour SCS Type II storm.

TREATMENT BMP SIZING

The City of Granger is located in the WDOE Region 2 of Eastern Washington. Therefore, all calculations shall be based on Region 2 methods recommended in the WDOE's SWMMEW for the sizing of stormwater BMPs. The following are design guidelines for volume-based treatment BMPs and flow-rate-based treatment BMPs.

Volume-based treatment BMPs are sized the same whether they are located upstream or downstream of a detention facility. The volume of runoff predicted for the proposed developed condition of a site will be calculated using the 24-hour SCS Type 1A storm with a 6-month return frequency (the 0.53-inch water quality design storm). The BMP will be sized to treat this amount of water, and will also be sized to pass the 25-year short-duration storm, either through or around the BMP, without damaging the BMP or dislodging pollutants from within it.

Flow-rate-based treatment BMPs are sized differently depending on whether they are located upstream or downstream from a detention facility. If the BMP is located upstream of a detention facility, or if there is no detention facility, the runoff flow rate predicted for the proposed developed condition of a site will be calculated using the 24-hour SCS Type II storm with a 6-month return frequency (the 0.53-inch water quality design storm). See Chapter 7 of the SWMMEW for design parameters. If the BMP is located downstream of a detention facility, it must be sized for the full 2- year release rate of the detention facility.

FLOW CONTROL

The criteria listed below shall apply to control of stormwater runoff flow and the designated design storms shall apply:

- Storm sewer facilities and pipelines shall be designed to carry at minimum the 25-year short-duration design storm described in the SWMMEW (0.92 inches of precipitation). Depending on the size of the basin, time of concentration and

infiltration rates, some infiltration facilities will also need to be checked using the 25-year, 24-hour storm (1.6 inches of precipitation, SCS Type 1A). At the City's discretion, if the facilities are critical to public health and safety, or significant property damage could occur, they shall be designed to successfully pass the 50-year or 100-year storm.

- Retention and detention basins shall be designed based on the 25-year, 24-hour long duration storm (1.6 inches of precipitation, SCS Type 1A). A secondary outlet or emergency spillway shall be provided to pass the 100-year storm (2.0 inches of precipitation, SCS Type II) without damage to the facility.

STREET DRAINAGE

Streets represent a large portion of the impervious area within a community. They can be used to convey a significant amount of stormwater; however, they must remain passable during storm events. To that end, streets may be used to convey local runoff to inlets, but stormwater must be removed at specific intervals in order to prevent excessive flooding. Guidance for flow carried within the street is presented below for the design storm (25-year) in Table 6-2, and the major storm (100-year) in Table 6-3. At intersections, the flow carried in one street may flow across the other street. Allowable cross street flow is listed in Table 6-4 for both the design storm and the major storm.

TABLE 6-2 25-YEAR STORMWATER RUNOFF ALLOWABLE STREET USE	
Street Classification	Maximum Pavement Encroachment
Residential	No curb overtopping. Flow may spread to crown of street.
Collector, Minor, and Principal Arterials	No curb overtopping. Flow spread must leave at least one lane in each direction free of water.
Freeway	No encroachment is allowed on any traffic lanes.

TABLE 6-3 100-YEAR STORMWATER RUNOFF ALLOWABLE STREET INUNDATION	
Street Classification	Maximum Pavement Encroachment
Residential	Residential dwellings and public, commercial, and industrial buildings shall not be inundated at the lowest finished floor elevation unless buildings are flood-proofed. The depth of water at the gutter flowline shall not exceed 12 inches.
Collector, Minor, and Principal Arterials	Residential dwellings and public, commercial, and industrial buildings shall not be inundated at the lowest finished floor elevation unless buildings are flood-proofed. The depth of water at the street crown shall not exceed 6 inches in order to allow operation of emergency vehicles. The depth of water at the gutter flowline shall not exceed 12 inches.
Freeway	No inundation is allowed.

TABLE 6-4 STORMWATER RUNOFF ALLOWABLE CROSS STREET FLOW		
Street Classification	25-Year Storm Runoff	100-Year Storm Runoff
Residential	6 inches in depth of gutter flowline, or up to crown of roadway, whichever is less.	12 inches in depth at gutter flowline.
Collector, Minor, and Principal Arterials	None.	6 inches or less over crown.
Freeway	None.	None.

In addition to the criteria for street carrying capacity, the following design criteria shall also apply to street drainage:

The following design storms shall apply:

- Flow in gutters and ditches shall be evaluated based on the 25-year design storm.
- Storm drain laterals shall carry the 25-year design storm, or be a minimum of 8-inches in diameter.
- Storm drain inlets on a slope shall handle the 25-year storm.
- Storm drain inlets in sag (low-point) shall handle the 50-year storm. (WSDOT design criteria). May be waived at City's discretion.

Stormwater runoff for new public streets shall be designed and constructed as required to the point where the adjoining property owner's responsibility for further extension begins. This typically requires an extension across the entire frontage of the property to the property line of the adjoining owner.

All storm sewer designs for new public streets shall be based upon an engineering analysis which takes into account total drainage areas, runoff rates, pipe and inlet capacities, and any other factors pertinent to the design.

All stormwater BMPs installed by the City in the public domain shall be maintained by the City, or by a subcontracted party.

Inlet spacing shall be designed in accordance with the WSDOT Hydraulics Manual, Chapter 5. Generally, inlet spacing shall not exceed 300 feet. There shall be a manhole or Type II catch basin installed at the intersection of two collector storm sewers. A collector storm sewer is a sewer servicing more than one catch basin.

SPECIAL PROVISIONS FOR STORM SEWERS AND DRAINAGE

The following sections of the WSDOT Standard Specifications have been amended or supplemented as described below and apply to the construction of public works storm sewer or drainage improvements within the City of Granger.

7-02 CULVERTS

7-02.2 Materials

Add the following:

Culvert pipe approved for use on a City project shall be as follows:

Aluminum Culvert Pipe: Aluminum Culvert Pipe shall meet the requirements of Section 9-05.5 of the Standard Specifications.

Steel Culvert Pipe: Steel Culvert Pipe shall meet the requirements of Section 9-05.4 of the Standard Specifications.

Corrugated Polyethylene Culvert Pipe: Corrugated Polyethylene (CPE) pipe, couplings, and fittings shall meet the requirements of Section 9-05.19 of the Standard Specifications.

7-04 STORM SEWERS

7 -04.1 Description

Supplement this section with the following:

The term "storm drain(s)" shall mean the same as storm sewer(s).

7-04.2 Materials

Supplement this section with the following:

The storm sewer (drain) pipe approved for use shall be as follows:

15-INCH THROUGH 36-INCH PIPE

Aluminum Storm Sewer Pipe: All Aluminum Storm Sewer pipe shall meet the requirements specified in Section 9-05.11 of the Standard Specifications and shall be 16 gauge with helical corrugations. A protective coating shall not be required. All corrugated metal pipe joints shall be flexible using rubber gasket joints. Gaskets shall be made of 3/8-inch thick by 12-inch minimum width closed cell synthetic sponge rubber, per ASTM D 1056, Grade SCE-43, fabricated in the form of a cylinder with a diameter of approximately 10 percent less than the nominal pipe size. The gasket shall be centered under the band and lapped an equal distance on the ends of the adjoining pipe sections. Coupling bands shall be used and shall conform to the provisions of Section 9-05.11(1) of the Standard Specifications. Coupling bands shall be made by the same

manufacturer as the pipe and shall be made of the same base material as the pipe which it connects.

Corrugated Polyethylene Storm Sewer Pipe: Corrugated Polyethylene (CPE) pipe, couplings, and fittings shall meet the requirements of Section 9-05.20 of the Standard Specifications.

8/10/12-INCH STORM DRAIN PIPE

Solid Wall PVC Storm Sewer Pipe
Corrugated Polyethylene Storm Sewer Pipe
High-Density Polyethylene (HDPE) Pipe
Polypropylene Storm Sewer Pipe

Where specified on the Plans, storm drain pipe shall be PVC pressure pipe conforming to the requirements of Section 9-30.1 (5)A and Ductile Iron conforming to the requirements of Section 9-30.1 (1).

UNDERDRAIN INFILTRATION SYSTEM MATERIALS

Pipe: Perforated Corrugated Polyethylene Underdrain (CPEP) pipe, couplings, and fittings shall comply with all the requirements of Section 9-05.2(8) of the Standard Specifications.

Drain Rock: Drain rock for use as backfill for the perforated underdrain pipe in the infiltration trench system shall be clean coarse aggregate conforming to the requirements of Gravel Backfill for Drywells, as specified in Section 9-03.12(5) of the Standard Specifications.

Construction Geotextile: Geotextile fabric for underground infiltration systems shall be moderate survivability, Class A as specified in Section 9-33.2(1).

7-04.3(1) Cleaning and Testing

7-04.3(1)A General

Supplement this section with the following:

No infiltration or exfiltration test will be required for storm drain pipe.

7-05 MANHOLES. INLETS. CATCH BASINS. AND DRYWELLS

7-05.2 Materials

Section 7-05.2 of the Standard Specifications shall be revised as follows:

Drain Rock: Backfill for drywells shall be Gravel Backfill for Drywells as specified in Section 9-03.12(5) of the Standard Specifications.

Manhole Metal Castings: All cast iron frames and covers shall be as specified in Section 9-05.15(1) of the Standard Specifications. All cast iron frames and covers to be used on

this project shall be of the type, weight, and size approved by the City of Granger, and shall be furnished by the Contractor. Covers for storm drain shall be stamped "STORM" or "DRAIN."

Precast Concrete Catch Basin: Catch basins shall be WSDOT Type 1, 1L, or 2 and constructed as shown on the City Standard Details.

Catch Basin Metal Castings: All frames and grates shall be capable of withstanding, with a reasonable margin of safety, a concentrated load of 20,000 pounds and shall be as specified in Section 9-05.15(2) of the Standard Specifications and WSDOT Standard Plan B-30.30-01 or B-30.40-01. The grate shall be ductile iron and "bicycle safe." The contact surfaces of the frame and grate shall be machine finished to a common plane and shall be so cast as to prevent rocking.

Construction Geotextile: All geotextile fabric for underground drainage applications shall be Moderate Survivability - Class B as specified in Section 9-33.2(1).

Precast Concrete Pretreatment Manhole: Stormwater pretreatment manholes shall be approved by the Washington State Department of Ecology (Ecology) with a General Use Level Designation (GULD), capable of 50% removal of fine (50 micron mean size) and 80% removal of coarse (125 micron mean size) total suspended solids (TSS) for influent concentrations greater than 100 mg/L, but less than 200 mg/L, as required by DOE.

Pretreatment manholes shall be constructed of pre-cast concrete manhole sections, flat top slab, and adjustment sections (similar to WSDOT Catch Basin Type 2, Standard Plan B- 10.20-01), with cast iron covers as described above. The pretreatment insert shall be constructed of fiberglass and/or steel materials that are corrosion resistant. Manhole safety steps shall be provided as shown on the Plans and the pretreatment insert shall act as a platform for maintenance purposes. Approved pretreatment manholes include Contech CDS, Stormceptor, Hydro International Downstream Defender, and Aqua-Swirl Concentrator.

The pretreatment manhole shall be capable of handling the specified water quality flows and shall incorporate a bypass within the unit to handle the specified peak flows. The pretreatment manhole shall be capable of incorporating multiple inlets/outlets, with the inlet and outlet pipes at 90 degrees to each other. Access to pretreatment insert ports and openings for maintenance shall be achieved through the cast iron cover(s).

7-05.3(1) Adjusting Manholes and Catch Basins to Grade

Delete and replace with the following:

Manholes, valve boxes, catch basins, and similar utility appurtenances and structures shall not be adjusted until the pavement is completed, at which time the center of each structure shall be relocated from references previously established by the Contractor.

The asphalt concrete pavement shall be cut and removed to a neat circle, the diameter of which shall be equal to the outside diameter of frame plus one (1) feet. The frame shall be placed on cement concrete blocks or adjustment rings and brought up to the desired grade. The base materials shall be removed and Class 3000 cement concrete

shall be placed within the entire volume of the excavation up to, but not to exceed, 2 inches below the finished pavement surface.

On the following day, a tack coat of asphalt shall be applied to the concrete, the edges of the asphalt concrete pavement, and the outer edge of the casting. HMA Cl. 3/8-Inch asphalt concrete shall then be placed and compacted with hand tampers and a patching roller.

The completed patch shall match the existing paved surface for texture, density, and uniformity of grade. The joint between the patch and the existing pavement shall then be sealed with emulsified asphalt and shall be immediately covered with dry paving sand before the tack has broken.

7-08 GENERAL PIPE INSTALLATION REQUIREMENTS

7 -08.1 General

Add the following:

All construction work shall be inspected by the City of Granger prior to backfilling. At least 48 hours notice shall be given to the City Public Works Department prior to backfilling.

The Contractor shall notify the Utility Notification Center (One Call Center) at least 48 hours prior to start of excavation so that underground utilities may be marked. Telephone number is 1-800-424-5555 or 811.

7-08.3(1)C Bedding the Pipe

Add the following:

The imported pipe bedding and select backfill to be utilized for the trench backfill shall be crushed gravel, placed and compacted in layers as designated by the Director of Public Works. Crushed gravel shall conform to Section 9-03.9(3) Crushed Surfacing Top Course.

7-08.3(3) Backfilling

Add the following:

Street crossing trenches and other locations, where directed, shall be backfilled for the full depth of the trench with Imported Select Backfill conforming to Section 9-03.9(3) Crushed Surfacing Base Course. The Public Works Director may require the use of Controlled Density Fill (CDF) for trench backfill in certain circumstances. The requirements for CDF are set forth in CHAPTER 7, Section 8-30 of these Special Provisions.

Mechanical compaction shall be required for all trenches. The density of the compacted materials shall be at least 95% of the maximum density as determined by ASTM D 1557 Test (Modified Proctor). The Contractor shall be responsible for scheduling, conducting, and paying for all testing required.

CHAPTER 7 -STREET IMPROVEMENTS

GENERAL REQUIREMENTS FOR STREETS

All new street design and construction must conform to these Design and Construction Standards of the City of Granger, the Granger Municipal Code, and the latest edition of the Standard Specifications.

TRAFFIC STUDIES

In order to provide sufficient information to assess a development's impact on the transportation system and level of service, the Public Works Director may require a traffic study to be completed by the Developer at the Developer's expense. This decision will be based upon the size of the proposed development, existing roadway condition, existing and expected, traffic volumes, accident history, expressed community concern, and other factors relating to transportation. Traffic studies shall be conducted under the direction of a traffic engineer or civil engineer licensed in the State of Washington and possessing special training and experience in traffic engineering. The level of detail and scope of the traffic study may vary with the size, complexity, and location of the proposed development. A traffic study shall, at a minimum, be a thorough review of the immediate and long-range effects of the proposed development on the City's transportation system. Guidelines for the traffic study shall be reviewed by the Public Works Director on a project basis. However, the ADT for the development shall be estimated using the trip generators found in the latest edition of the Trip Generation Manual published by ITE.

STREET REQUIREMENTS

Arterial streets serve as the high volume corridors that connect the major traffic generators and shall be designed with a minimum seventy (70) foot-wide Right of Way and forty-four (44) foot-wide roadway surface face of curb to face of curb. Face of curb radius at intersection shall be a minimum of 50 feet and the street centerline radius shall be designed to a minimum 40 mph design speed or as approved by the Public Works Director. Both Arterial and Collector streets shall be designed for a WB-50 vehicle and HS-25 loadings.

Collector streets shall be designed with a minimum sixty (60) foot-wide right of way and a forty (40) foot-wide roadway surface face of curb to face of curb. Face of curb radius at intersection shall be a minimum of forty (40) feet and the street centerline radius shall be designed to a minimum 35 mph design speed or as approved by the Public Works Director.

Local Access (Residential) streets shall be designed with a minimum fifty (50) foot-wide right of way and forty (30) foot-wide roadway surface curb to curb. Face of curb radius at intersection shall be a minimum of twenty-five (25) feet and street centerline radius shall be designed to a minimum of 30 mph design speed or as approved by the Public Works Director.

The maximum length of a cul-de-sac street shall be 600 feet measured along the street centerline from the nearest street intersection to the throat of the cul-de-sac. Where it is not feasible to construct a cul-de-sac turnaround, the City may allow the use of an "L" or "Hammerhead" turnaround upon approval by the Public Works Director. The minimum cul-de-sac right-of-way is a radius of 60 feet and a curb radius of 48 feet. Refer to the latest edition of the International Fire Code, Appendix D, Fire Apparatus Access Roads.

A subdivision of 15 or more lots shall have two or more access points. Street intersection angles shall not be less than 80 degrees. Offset street intersections shall not be less than 200 feet for arterial and collector streets and 100 feet for local access streets. Street grades shall be kept to a minimum and no street grade shall be less than five tenths (0.50) percent or greater than twelve (12) percent. Vertical curves shall be designed when the grade difference is greater than two (2) percent.

Sidewalks shall be installed on both sides of Arterial and Collector streets, and one side of Local Access streets. Sidewalks shall be constructed when homes/businesses are constructed and shall be completed prior to occupancy.

Standard cement concrete curb and gutter and sidewalk(s) shall be installed along all new streets unless otherwise approved by the City of Granger. Cement concrete rolled curb may be approved for local access streets by the Public Works Director, on a case-by-case basis, except for the corner lot at an intersection, where the curb shall be full height. There shall be a 10-foot long transition from the full height curb to the rolled curb.

Driveways shall be located on the lowest classification of roadway abutting the development. Driveways accessing onto arterial streets are discouraged and shall be limited. Driveway widths and locations are limited to one per lot as approved by the Public Works Director. A "Corner" lot driveway shall be located as far as possible from the street intersection.

A street light shall be installed at each street intersection, at mid-block if the block is longer than 450 feet, and at ends of cul-de-sacs. Street light spacing along arterial and collector streets shall be no more than two hundred and twenty five (225) feet apart. Street lights shall meet the design and placement requirements of these Design and Construction Standards, for approval consideration by the City Public Works Director and local electric utility.

In all new developments, monuments with cover caps and cases shall be installed at the centerline of street intersections, horizontal geometry points of the centerline, and at other locations as directed by the Public Works Director.

Traffic control signs and sign posts shall be provided and installed by the developer in accordance with the latest edition of the Manual of Uniform Traffic Control Devices (MUTCD) and City Design and Construction Standards.

SPECIAL PROVISIONS FOR STREETS

The following sections of the Standard Specifications have been amended or supplemented as described below.

2-01 CLEARING, GRUBBING, AND ROADSIDE CLEANUP

2-01.1 Description

Supplement this section with the following:

In no case shall the Contractor be required to clear and grub beyond the right-of-way line, except as specifically directed by the City or noted on the Plans to remove trees, stumps, shrubs, or other items which, by proximity or due to root growth, would constitute a hazard to the public or endanger the facility. All work beyond the right-of-

way line shall be coordinated with affected property owner(s) per Section 1-07.24 Rights of Way.

The Contractor shall temporarily remove and later replace to its original condition or relocate nearby as directed, all mail boxes, small trees, shrubs, street signs and posts, culverts, irrigation facilities, concrete or rock walls, or other similar obstructions which lie in or near the line of work and are not intended for removal. Should any damage be incurred, the cost of replacement or repair shall be borne by the Contractor.

2-01.3(5) Fencing (New Section)

Add the following new section:

The Contractor shall be required to carefully remove all existing fencing located within or near the proposed alignments. All fencing materials to be removed and replaced shall be temporarily placed on the adjacent properties or stored as directed by the City. The removal and replacement of all fencing shall be done at the Contractor's expense. Any fencing that is to be reset shall be relocated and reset by the Contractor along the property lines or as directed by the City.

2-02 REMOVAL OF STRUCTURES AND OBSTRUCTIONS

2-02.3 Construction Requirements

2-02.3(2) Removal of Bridges, Box Culverts, and Other Drainage Structures

Supplement this section with the following:

Where structures or installations of concrete, brick, blocks, etc., interfere with the construction, they shall be removed and any pipe openings shall be properly plugged watertight with Class 3000 concrete, or with mortar and masonry, blocks, or brick. The removal and plugging of pipes shall be considered as incidental to the construction and costs thereof and shall be included in other items of work.

Where the structures are removed, the voids shall be backfilled with suitable, job-excavated material and compacted, and such work shall be considered as incidental to the removal work. If the City determines the job-excavated material to be unsuitable for backfill, the Contractor shall place ballast or crushed surfacing material as directed by the City.

2-03 ROADWAY EXCAVATION AND EMBANKMENT

2-03.1 Description

Supplement this section with the following:

The Contracting Agency will reference all known existing monuments or markers relating to subdivisions, plats, roads, street centerline intersections, etc. The Contractor shall take special care to protect these monuments or markers and also the reference points. In the event the Contractor is negligent in preserving such monuments and markers, the points will be reset by a licensed surveyor at the Contractor's expense.

2-03.3 Construction Requirements

2-03.3(14)D Compaction and Moisture Control Tests

Delete this section and replace it with the following:

Compaction shall be 95% of maximum density as determined by ASTM D 1557 (Modified Proctor). The Developer/Contractor shall be responsible for scheduling compaction testing with a certified materials testing laboratory. Compaction tests shall meet the frequency of section 1-05.6(1) of these Special Provisions.

2-07 WATERING

2-07.1 Description

Supplement this section with the following:

The Contractor shall be solely responsible for dust control on the Developer's project and shall protect motoring public, adjacent homes and businesses, orchards, crops, and school yards from damage due to dust, by whatever means necessary. The Contractor shall be responsible for any claims for damages and shall protect the City, Yakima County, and Consultant from any and all such claims.

When directed by the City, the Contractor shall provide water for dust control within two hours of such order and have equipment and manpower available at all times including weekends and holidays to respond to orders for dust control measures.

4-04 BALLAST AND CRUSHED SURFACING

4-04.3 Construction Requirements

4-04.3(5) Shaping and Compaction

Supplement this section with the following:

The Contractor shall notify the City when he is ready for in-place ballast, base course, or top course density tests. The Developer/Contractor shall be responsible for scheduling compaction testing with a certified materials testing laboratory. Compaction tests shall meet the frequency of section 1-05.6(1) of these Special Provisions. Placement of successive courses of aggregate or asphalt concrete shall not proceed until density requirements are met.

5-04 HOT MIX ASPHALT

5-04.3(3)A Material Transfer Device/Vehicle

Delete this section in its entirety.

5-04.3(5)C Crack Sealing

Supplement this section with the following:

The Contractor shall provide traffic control during crack sealant application. The Contractor shall conduct his operations so as to maintain two-way traffic and a safe work area at all times.

The Contractor shall provide written notification to businesses and property owners a minimum of 24 hours, and a maximum of 72 hours, in advance of commencing crack sealing operations. The notices shall provide a brief explanation of the scope of work and the name and phone number of a contractor contact person. The notice shall be in both English and Spanish languages. The Contractor shall provide barricades, cones, etc. as required for area closures following distribution of notices.

5-04.3(7)A2 Statistical or Nonstatistical Evaluation

Delete this section and replace it with the following:

The Contractor shall be responsible for verification of the mix design.

5-04.3(8)A Acceptance Sampling and Testing -HMA Mixture

5-04.3(8)A1 General

Delete this section and replace it with the following:

Acceptance of HMA shall be as provided under Nonstatistical or Commercial evaluation.

Commercial evaluation will be used for Commercial HMA and for other classes of HMA in the following applications: Sidewalks, road approaches, ditches, slopes, paths, trails, gores and other nonstructural applications as approved by the City. Sampling and testing of HMA accepted by commercial evaluation will be at the option of the City. The proposal quantity of HMA that is accepted by commercial evaluation will be excluded from the quantities used in the determination of Nonstatistical evaluation.

Commercial HMA can be used for patching utility or conduit trenches less than 24 inches in width.

5-04.3(10) Compaction

5-04.3(10)B Control

Delete this section and replace with the following:

HMA used in traffic lanes, including lanes for ramps, truck climbing, weaving, and speed change, and having specified compacted course thickness greater than 0.10 foot, shall be compacted to a specified level relative density. The specified level of relative density shall be a minimum of 91.0 percent of the reference maximum density as determined by WSDOT for AASHTO T 209. The reference maximum density shall be determined as the moving average of the most recent five determinations for the lot of HMA being placed. The specified level of density attained will be determined by five

nuclear gauge tests taken in accordance with WAQTC FOP TM8 and WSDOT SOP T-729 on the day the mix is placed (after completion of the finish rolling) at locations determined by the stratified random sampling procedure conforming to WSDOT Test Method 716 within each density lot. The quantity represented by each density lot will be no greater than a single day's production or approximately 400 tons, whichever is less. The Contractor will furnish the City with a copy of the results of all acceptance testing performed in the field within one working day.

In addition to the randomly selected locations for tests of density, the City may also isolate from a normal lot any area that is suspected of being defective in relative density. Such isolated material will not include an original sample location. A minimum of five (5) randomly located density tests will be taken.

Control lots not meeting the minimum density standard shall be removed and replaced with satisfactory material at the Contractor's expense.

HMA constructed under conditions other than those listed above shall be compacted on the basis of a test point evaluation of the compaction train. The test point evaluation shall be performed in accordance with instructions from the City. The number of passes with an approved compaction train, required to attain the maximum test point density, shall be used on all subsequent paving.

5-04.3(11) Reject Work

Supplement this section with the following:

Delete all references to Combined Pay Factor (CPF). HMA not meeting the quality requirements of the Contract shall be rejected, including use of HMA CI. 3/8-Inch.

5-04.3(13) Surface Smoothness

Supplement this section with the following:

Where directed by the City, the Contractor shall feather the HMA pavement in a manner to produce a smooth-riding connection to the existing pavement.

5-04.3(14) Planing Bituminous Pavement

The third paragraph of this section is deleted and replaced with the following:

The ground HMA material resulting from the pavement planing operation shall become the property of the City when so desired.

The Contractor shall haul the material to the City Shop located at 503 Main Street and stockpile the material at a location as directed by the City.

All other debris resulting from the planing operation shall become the property of the Contractor and be disposed of in accordance with Section 2-03.3(7)C.

5-04.3(17) Paving Under Traffic

Delete the following in the last paragraph:

"except the costs of temporary pavement markings"

5-04.3(19) Sealing of Pavement Surfaces

Revise the first sentence to read:

"The Contractor shall apply a fog seal to all travel lanes and allow it to cure prior to opening the lane to traffic, when the wearing course is placed after October 1 and before April 1."

5-04.5(1) Quality Assurance Price Adjustments

Delete this section in its entirety.

8-04 CURBS, GUTTERS, AND SPILLWAYS

8-04.3 Construction Requirements

8-04.3(1) Cement Concrete Curbs, Gutters, and Spillways

Supplement this section with the following:

Cement concrete traffic curb and gutter shall be as shown on the City's Standard Plans. Standard cement concrete traffic curb and gutter as shown shall be used on the roadway as shown on the Plans. Depressed or "Driveway" cement concrete traffic curb and gutter as shown shall be used at all driveway entrances and sidewalk ramp locations as shown on the Plans and as directed in the field by the City. Cement concrete curb and gutter which does not comply with the City's details shall be removed and replaced at the Contractor's expense.

First-class workmanship and finish will be required on all portions of concrete curb and gutter work. Quality of workmanship and finish will be evaluated continuously and will be based solely upon the judgment of the City. The Contractor shall be required to construct a minimum 20 linear foot section of curb and gutter which demonstrates quality which is acceptable by the City. This "model" section will be referenced during construction for comparison to newly poured curb. If at any time it is found that quality is unacceptable, work shall be immediately stopped, and no additional curb and gutter shall be placed. Cement concrete curb and gutter which does not comply with the section details on the Plans, or in the City's opinion does not demonstrate first-class workmanship and finish, shall be removed and replaced at the Contractor's expense. Should the Contractor's equipment or methods be unable to produce curb and gutter meeting the requirements of the Details and Specifications, no further curb and gutter construction will be allowed until corrections have been made to said equipment or methods.

8-06 CEMENT CONCRETE DRIVEWAY ENTRANCES

8-06.3 Construction Requirements

Supplement this section with the following:

The concrete driveway entrance/sidewalk shall be six (6) inches in thickness.

8-13 MONUMENT CASES

8-13.1 Description

Replace this section with the following:

This work consists of furnishing and placing monuments and monument cases and covers, in accordance with the City's Standard Drawing S14 and these Specifications, in conformity with the lines and locations shown in the Plans or as staked.

8-13.2 Materials

Supplement this section with the following:

Hot Mix Asphalt	5-04
Reinforcing Steel	9-07

8-13.3 Construction Requirements

Replace this section with the following:

Survey monument shall be set under the direction of a Land Surveyor licensed to practice in the State of Washington. The City shall be provided with the required data for survey monument certification as required by Yakima County and Washington State.

The Contractor shall excavate for and install the new monument, including the case and cover. The top of the monument cap shall be 3 inches below finish grade and the case and cover shall be set 1/4 inch to 1/2 inch below finish grade.

Monument case, cover and risers shall meet the requirements of section 9-22 as manufactured by Olympic Foundry or approved equal.

8-14 CEMENT CONCRETE SIDEWALKS

8-14.3 Construction Requirements

8-14.3(3) Placing and Finishing Concrete

Supplement this section with the following:

All sidewalks not located in driveway entrance areas shall be four (4) inches in thickness. All concrete approaches located behind a depressed curb and gutter section or at any driveway location shall be six (6) inches in thickness.

Sidewalks shall be marked across the entire width every five (5) feet and with preformed asphalt impregnated joint fillers 3/8-inch thick every twenty (20) feet. Concrete sidewalk shall be cured in accordance with Section 5-05.3(13)A of the Standard Specifications. Application of the curing compound shall be in accordance with the manufacturer's recommendations. Failure to properly secure or seal the cement concrete sidewalk will require the Contractor to remove and replace the sidewalk section at his expense.

First-class workmanship and finish will be required on all portions of cement concrete sidewalk work. Quality of workmanship and finish will be evaluated continuously and will be based solely upon the judgment of the City. If at any time it is found that quality is unacceptable, work shall be immediately stopped, and no additional sidewalk shall be placed. Cement concrete sidewalk which does not comply with the section details on the Plans, or in the City's opinion does not demonstrate first-class workmanship and finish, shall be removed and replaced at the Contractor's expense. Should the Contractor's equipment or methods be unable to produce sidewalk meeting the requirements of the Plans and Specifications, no further sidewalk construction will be allowed until corrections have been made to said equipment or methods.

8-21 PERMANENT SIGNING

8-21.2 Materials

Supplement this section with the following:

Reflective background sheeting material shall be Type III for regulatory signs and Type I for all other signs.

Sign posts for permanent traffic control signing shall be 2"x2" 12-gauge perforated steel tubing. Socket sleeves for the sign post shall be 2-1/4"x 2-1/4"x30" 12-gauge perforated steel tubing.

8-21.3 Construction Requirements

Supplement this section with the following:

Socket sleeves for sign posts shall be set in 12" diameter x 12" deep base of class 3000 cement concrete at finish grade so that erected signs will be plumb with roadway. The Contractor shall correct any misaligned socket sleeves at his own expense.

8-30 CONTROLLED DENSITY FILL (NEW SECTION)

The following new section shall be added to the Standard Specifications:

8-30.1 General

Controlled Density Fill (CDF) may be required for street crossings by the Public Works Director. It shall be a mixture of Portland Cement, fly ash, aggregate, water, and admixtures proportioned to provide a non-segregating, self-consolidating, free-flowing material which will result in a hardened, dense, non-settling fill.

8-30.2 Materials

Materials shall meet the requirements of the following Sections of the Standard Specifications:

Portland Cement	9-01 Type II
Fly Ash	Class For C
Aggregates	9-03.1
Water	9-25
Admixtures	9-23.6

8-30.3 Construction Requirements

8-30.3(1) Construction Materials

The CDF shall be a mixture of Portland Cement, fly ash, aggregate, water, and admixtures which has been batched and mixed in accordance with Section 6-02.3 of the Standard Specifications.

The following table provides a guideline for proportioning the Controlled Density Fill for this project. The final mix provided by the Contractor shall result in a material which is excavatable by machine with a maximum unconfined compressive strength of 300 psi.

Water	50 gals per cubic yard
Cement	50 lbs per cubic yard
Fly Ash	250 lbs per cubic yard
Aggregate	3,200 lbs per cubic yard

The above table provides a guideline for the CDF mixture. The weights shown are only an estimate of the amount to be used per cubic yard of CDF. Actual amounts may vary from those shown as approved by the City or approved mix data from similar projects which provided proper strength, workability, consistency, and density.

8-30.3(7) Placing Controlled Density Fill

The floatable CDF shall be placed in the trench area where directed by the City and brought up uniformly to the top of the pipe zone backfill as shown on the Plans. In the cases where existing concrete slabs have been undermined by excavation, the Contractor shall ensure that the CDF is flowed completely under the slab.

Mixing and placing may be started if weather conditions are favorable, when the temperature is at least 34°F and rising. At the time of placement, CDF must have a temperature of at least 40°F. Mixing and placing shall stop when the temperature is 38°F and falling. Each filling stage shall be as continuous an operation as practicable. CDF shall not be placed on frozen ground.

The trench section to be filled with CDF shall be contained at either end of trench section by bulkhead or earth fill.

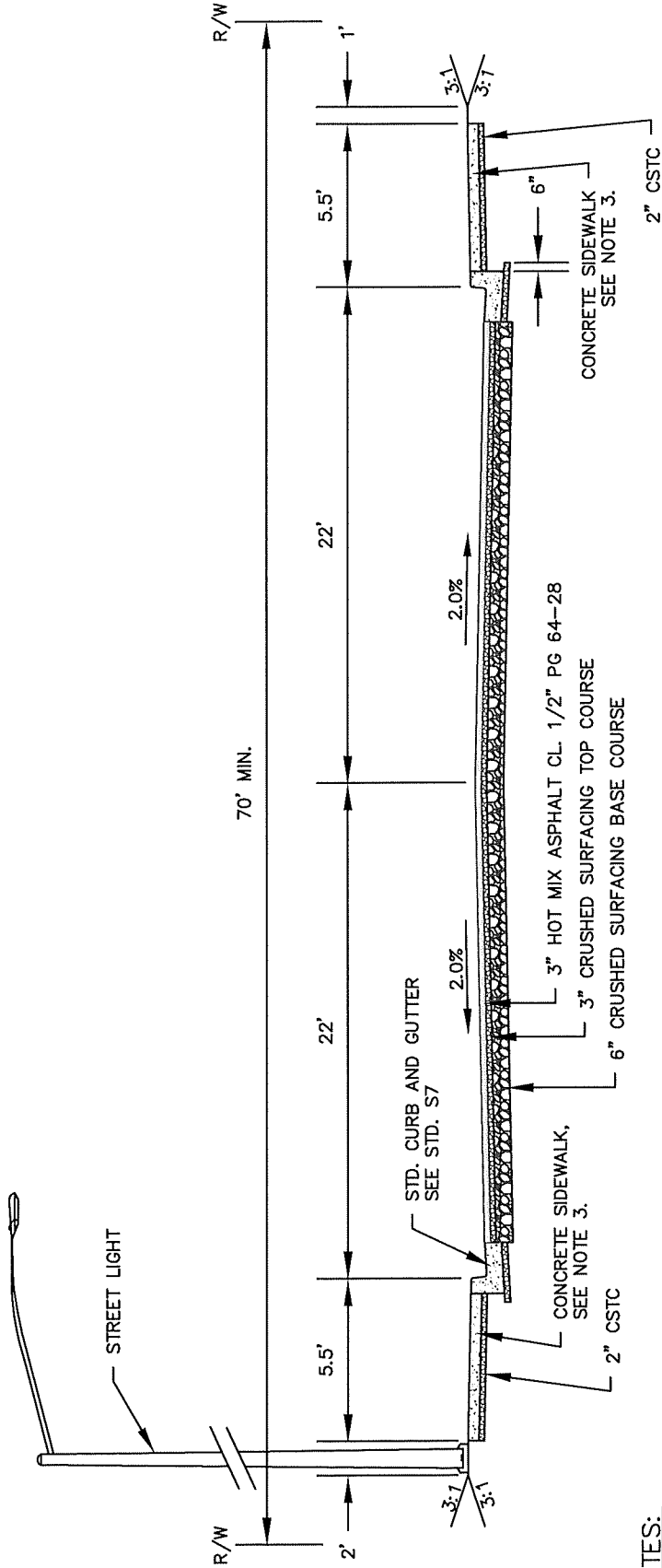

NOTES:

1. ALL THICKNESSES ARE COMPACTED DEPTHS.
2. BACK SLOPES SHALL BE 3:1 UNLESS OTHERWISE APPROVED BY PUBLIC WORKS DIRECTOR.
3. CONCRETE SIDEWALKS TO BE:
6" THICK AT DRIVEWAYS,
4" THICK AT ALL OTHER LOCATIONS.

NOTE:

ONLY THE LATEST DETAIL, AS APPROVED BY THE DIRECTOR OF PUBLIC WORKS, SHALL BE USED.

REV.	DATE	DESCRIPTION
ORIG.	3/17	-

CITY OF GRANGER-STD. DETAIL

TYPICAL ARTERIAL
ROADWAY SECTION

DWG #

S2

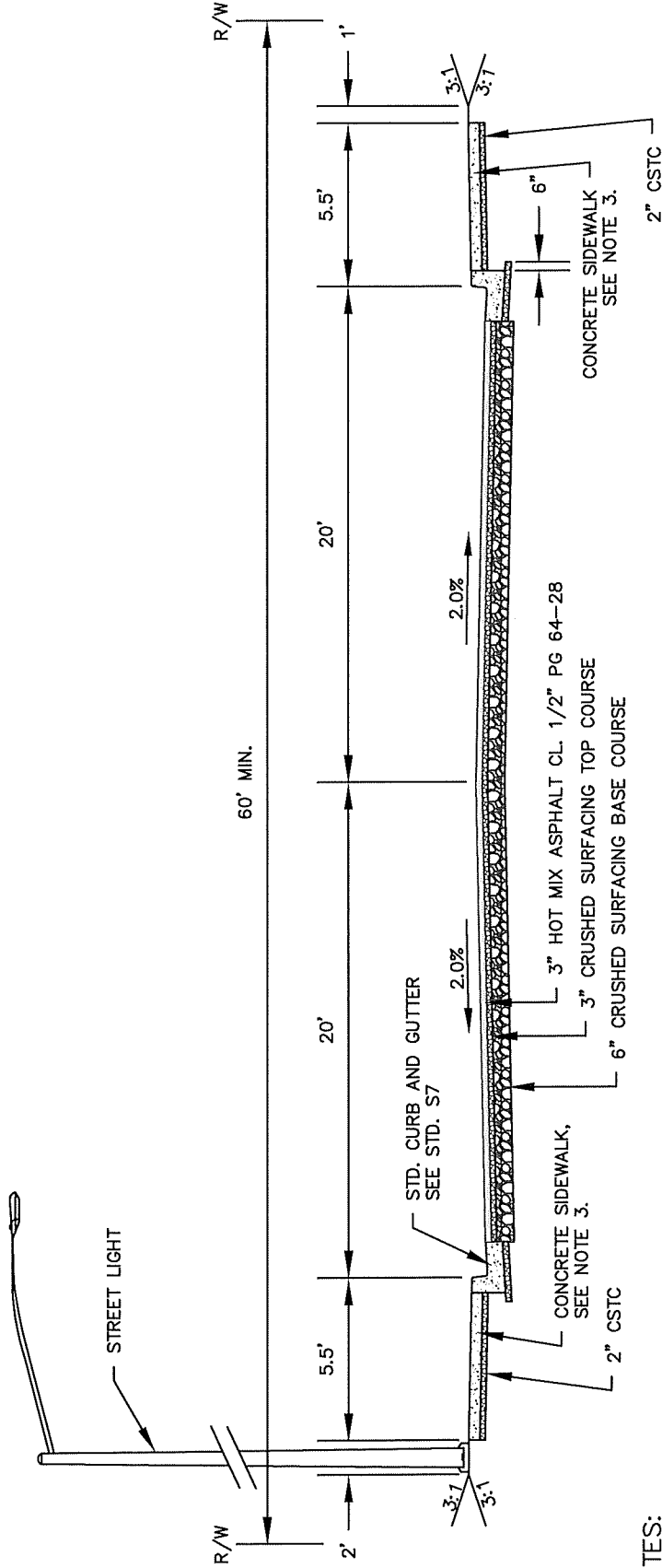

NOTES:

1. ALL THICKNESSES ARE COMPACTED DEPTHS.
2. BACK SLOPES SHALL BE 3:1 UNLESS OTHERWISE APPROVED BY PUBLIC WORKS DIRECTOR.
3. CONCRETE SIDEWALKS TO BE:
 6" THICK AT DRIVEWAYS,
 4" THICK AT ALL OTHER LOCATIONS.

NOTE:

ONLY THE LATEST DETAIL, AS APPROVED BY THE DIRECTOR OF PUBLIC WORKS, SHALL BE USED.

REV.	DATE	DESCRIPTION
ORIG.	3/17	-

CITY OF GRANGER-STD. DETAIL

TYPICAL COLLECTOR
ROADWAY SECTION

DWG #

S3

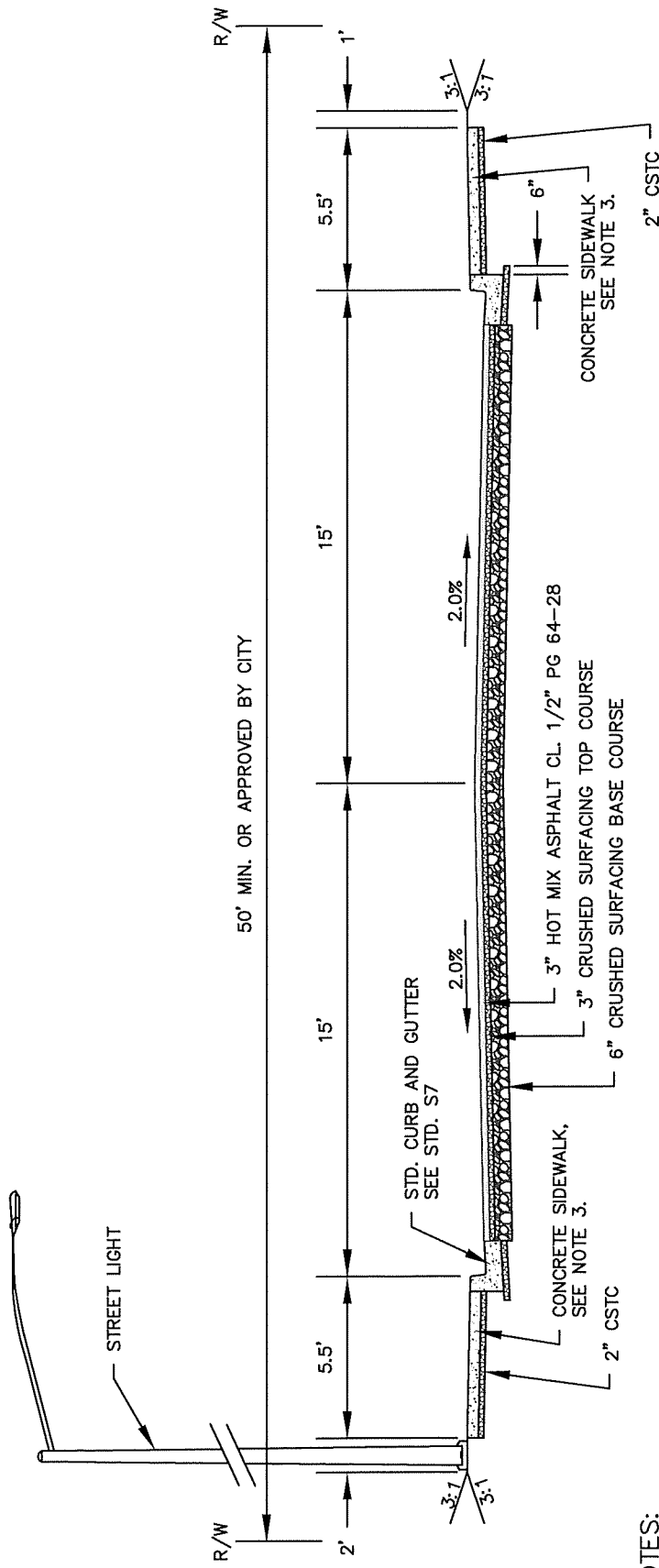

NOTES:

1. ALL THICKNESSES ARE COMPACTED DEPTHS.
2. BACK SLOPES SHALL BE 3:1 UNLESS OTHERWISE APPROVED BY PUBLIC WORKS DIRECTOR.
3. CONCRETE SIDEWALKS TO BE:
6" THICK AT DRIVEWAYS,
4" THICK AT ALL OTHER LOCATIONS.
4. IF ROLLED CURB AND GUTTER IS APPROVED, SIDEWALK SHALL BE 6" THICK.

NOTE:

ONLY THE LATEST DETAIL, AS APPROVED BY THE DIRECTOR OF PUBLIC WORKS, SHALL BE USED.

REV.	DATE	DESCRIPTION
ORIG.	3/17	-

CITY OF GRANGER-STD. DETAIL

TYPICAL LOCAL ACCESS ROADWAY SECTION

DWG #

S4

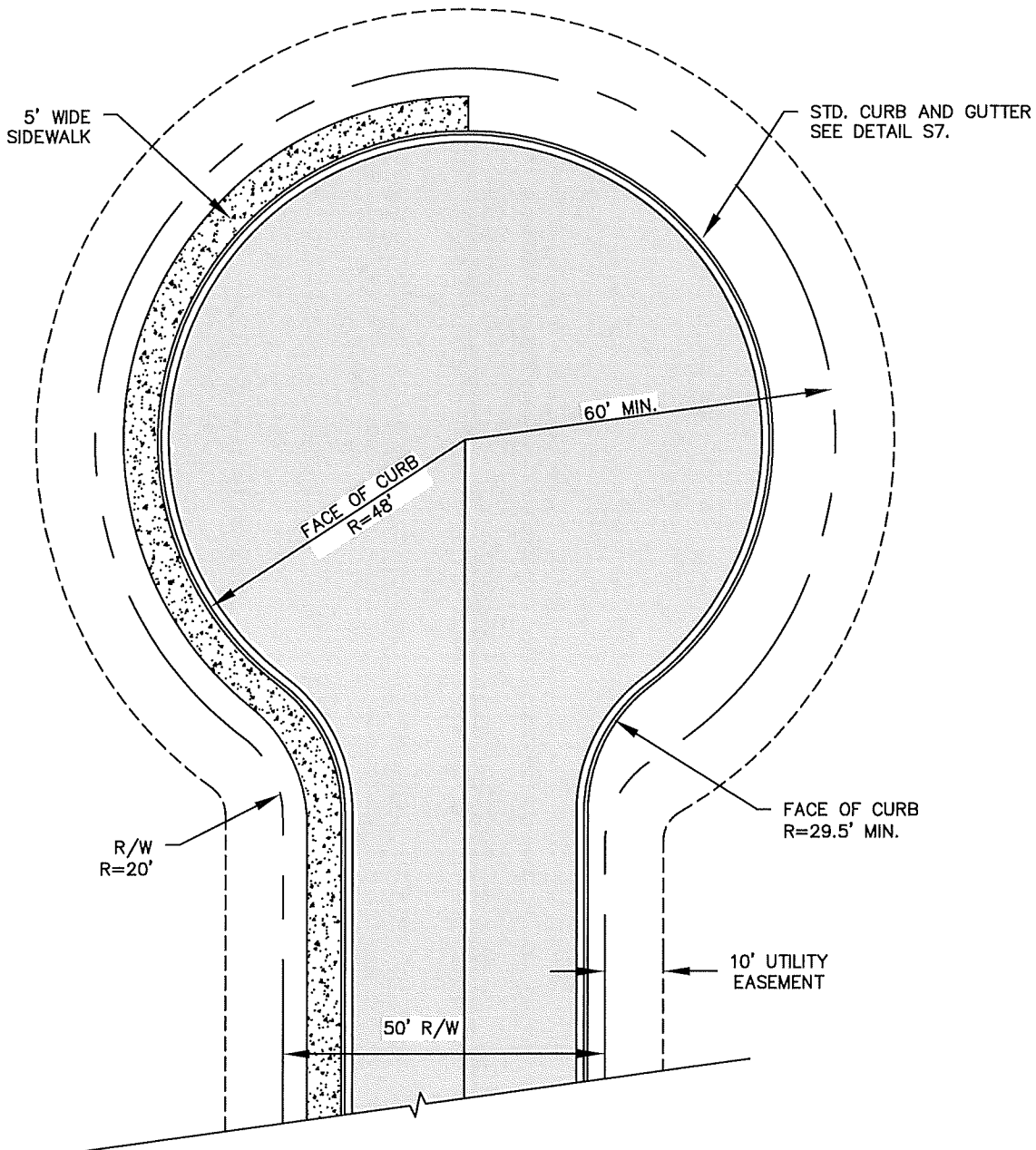

PLAN VIEW
NOT TO SCALE

NOTE:
CUL-DE-SAC STREETS SHALL BE A
MAXIMUM OF 600 FEET IN LENGTH.

NOTE:

ONLY THE LATEST DETAIL, AS APPROVED BY THE
DIRECTOR OF PUBLIC WORKS, SHALL BE USED.

ORIG.	3/17	-
REV.	DATE	DESCRIPTION

CITY OF GRANGER-STD. DETAIL

CUL-DE-SAC LAYOUT

DWG #

S5

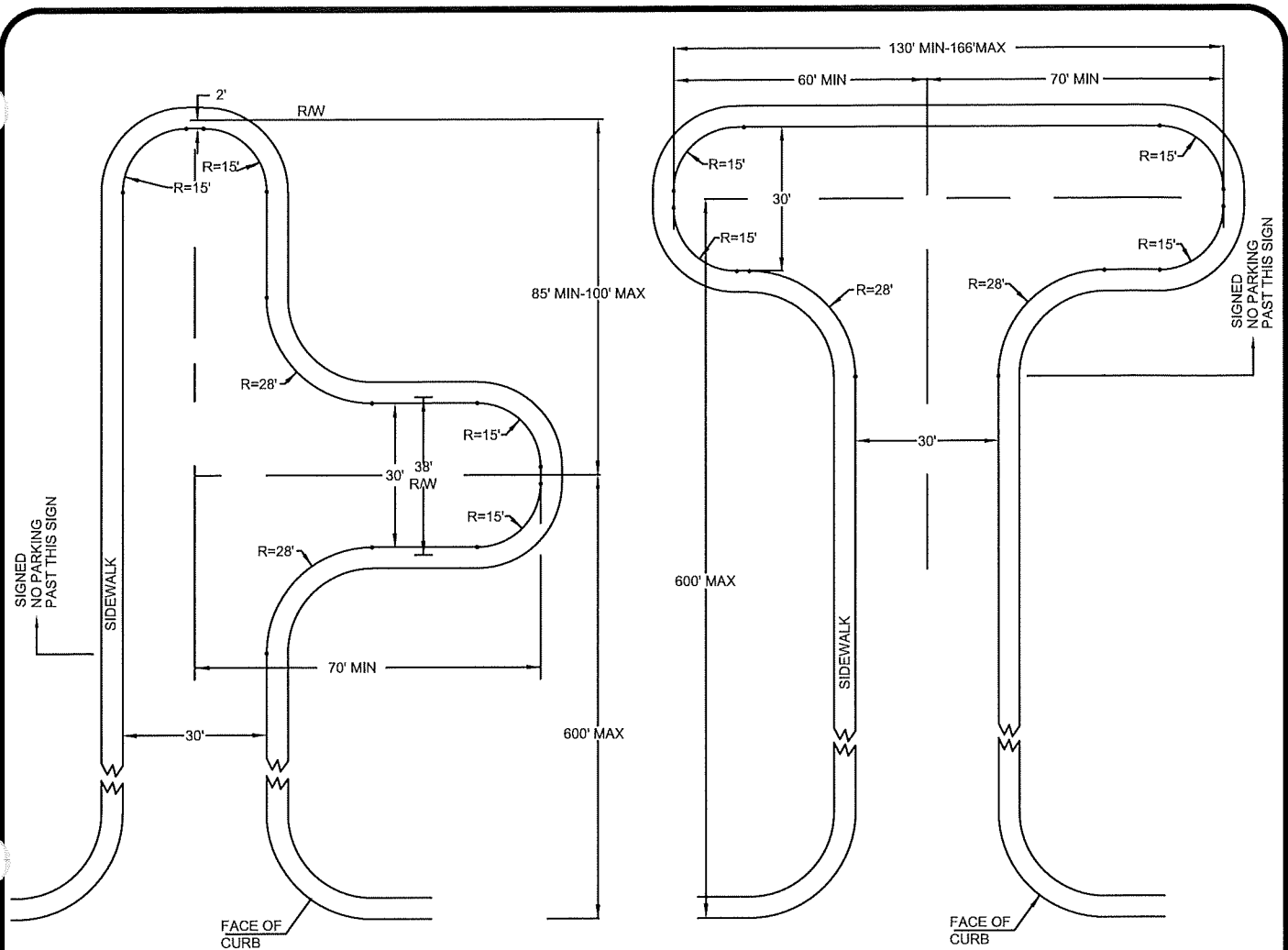

NOTES:

WITH THE PRIOR APPROVAL OF BOTH THE CITY ENGINEER AND FIRE MARSHAL, AN ALTERNATE TURN-AROUND MAY BE USED. APPROVAL WILL BE CONSIDERED ONLY WHEN THE FOLLOWING MINIMUM CRITERIAS ARE MET.

1. ALL ALTERNATE TURN-AROUNDS MUST COMPLY WITH THE INTERNATIONAL FIRE CODE, APPENDIX D
2. MUST BE AN IN-FILL AREA BETWEEN DEVELOPED RESIDENTIAL LOTS WHERE, A FULL SIZE CUL-DE-SAC WOULD NOT BE PRACTICAL AS DETERMINED BY THE CITY ENGINEER AND FIRE MARSHAL; OR MUST BE AN IN-FILL AREA BETWEEN LOTS ZONED FOR OTHER THAN RESIDENTIAL USE, WHERE A FULL SIZED CUL-DE-SAC WOULD NOT BE PRACTICAL, AS DETERMINED BY THE CITY ENGINEER AND FIRE MARSHAL: AND
3. THE UNDEVELOPED LOT MUST HAVE A MAXIMUM LOT WIDTH OF 180 FEET; AND,
4. THE MAXIMUM LENGTH OF THE DEAD END STREET WILL BE 600 FEET.
5. AN ALTERNATE DESIGN, SIMILAR TO THIS DRAWING, MAY BE SUBMITTED FOR CONSIDERATION OF APPROVAL BY BOTH THE CITY ENGINEER AND FIRE MARSHAL.
6. THE TURN AROUND AREA SHALL BE SIGNED FOR NO PARKING.

ORIG.	3/17	-
REV.	DATE	DESCRIPTION

NOTE:

ONLY THE LATEST DETAIL, AS APPROVED BY THE DIRECTOR OF PUBLIC WORKS, SHALL BE USED.

CITY OF GRANGER-STD. DETAIL

ALTERNATE
TURN-AROUND

DWG #

S6

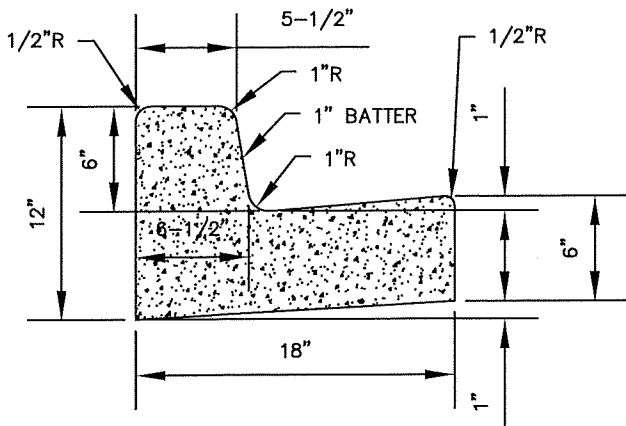

STANDARD CURB AND GUTTER

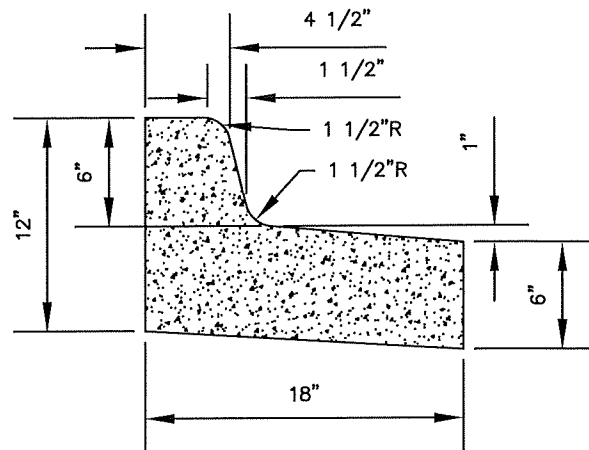

CONCRETE SPILL CURB

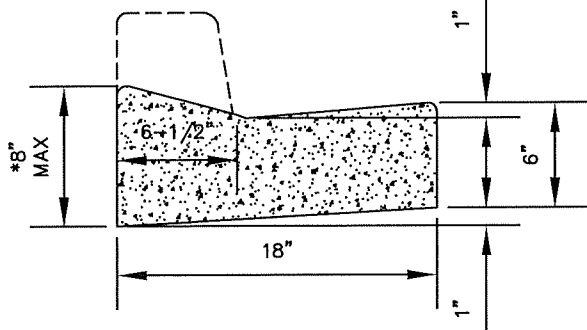

DEPRESSED - DRIVEWAYS

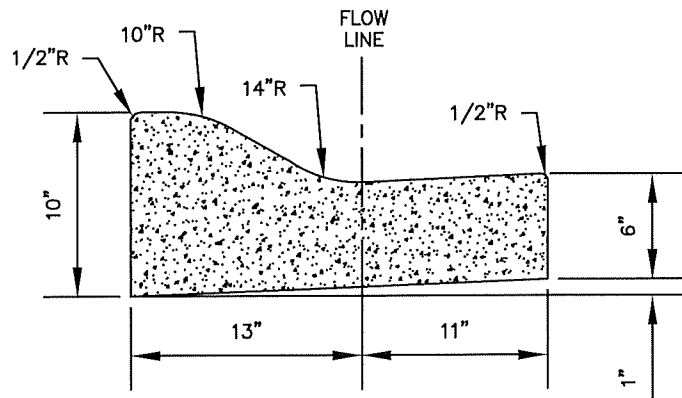

ROLLED CURB

NOTE:

- * AS DIRECTED BY ENGINEER. MAY VARY DEPENDING UPON GRADE OF SIDEWALK AND DRIVEWAY BEYOND CURB.

NOTE:

TOP OF CURB ELEVATION SHOWN IS TOP OF STANDARD CURB AND GUTTER. SUBTRACT 0.17' FOR TOP OF ROLLED CURB.

NOTES:

1. 3/8" THICK MASTIC EXPANSION JOINT TO BE PLACED AT ALL POINTS OF TANGENCY.
2. FOR STATIONARY FORM CONSTRUCTION STANDARD PLATES AND HALF PLATES TO BE PLACES AT 10'-0" INTERVALS.
3. FOR SLIP-FORM CONSTRUCTION, PROVIDE FULL DEPTH JOINTS AT 10'-0" INTERVALS.
4. BACKFILL BEHIND CURB SHALL EXTEND FROM TOP OF CURB BACK TO A POINT AS DIRECTED BY THE PUBLIC WORKS DIRECTOR. THE TOP 4" OF BACKFILL OR EXISTING MATERIAL SHALL BE OF FINE GRADED MATERIAL, SUITABLE FOR LAWNS, AND BE DAMPENED AND THEN BE MECHANICALLY COMPACTED TO OBTAIN A REASONABLE LEVEL OF COMPACTION.

NOTE:

ONLY THE LATEST DETAIL, AS APPROVED BY THE DIRECTOR OF PUBLIC WORKS, SHALL BE USED.

ORIG.	3/17	-
REV.	DATE	DESCRIPTION

CITY OF GRANGER-STD. DETAIL

CONCRETE CURB AND GUTTER

DWG #

S7

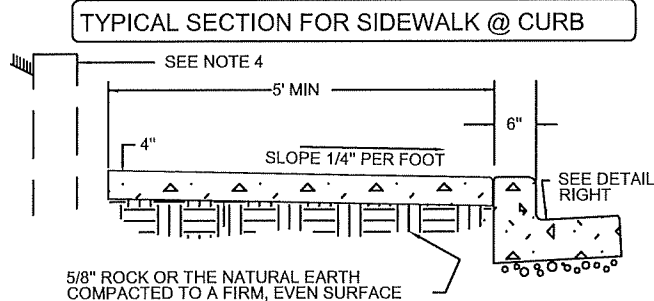
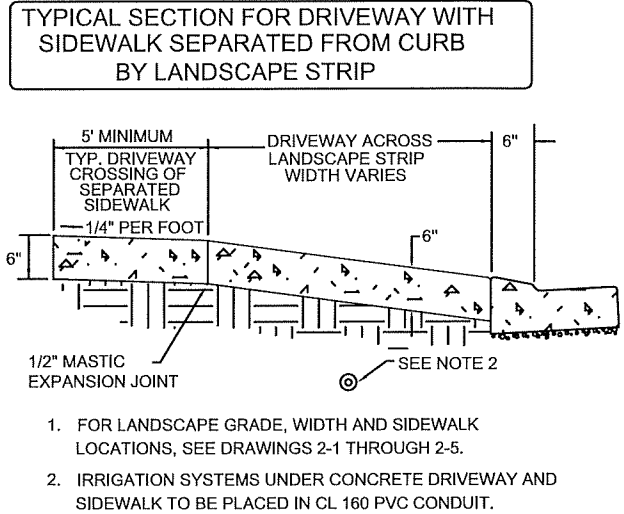
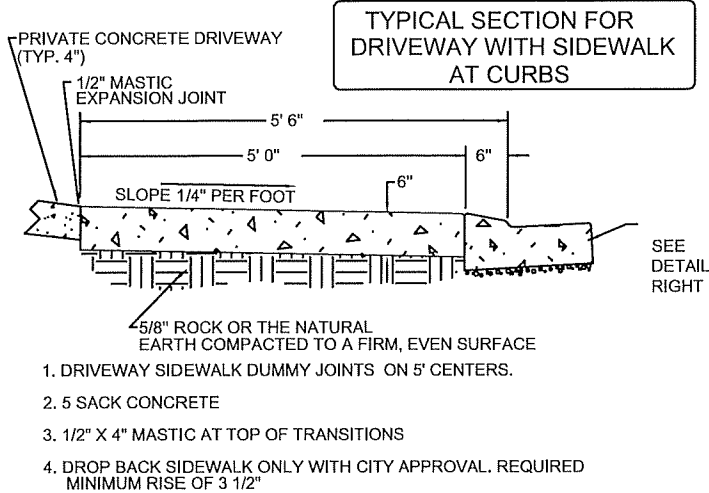
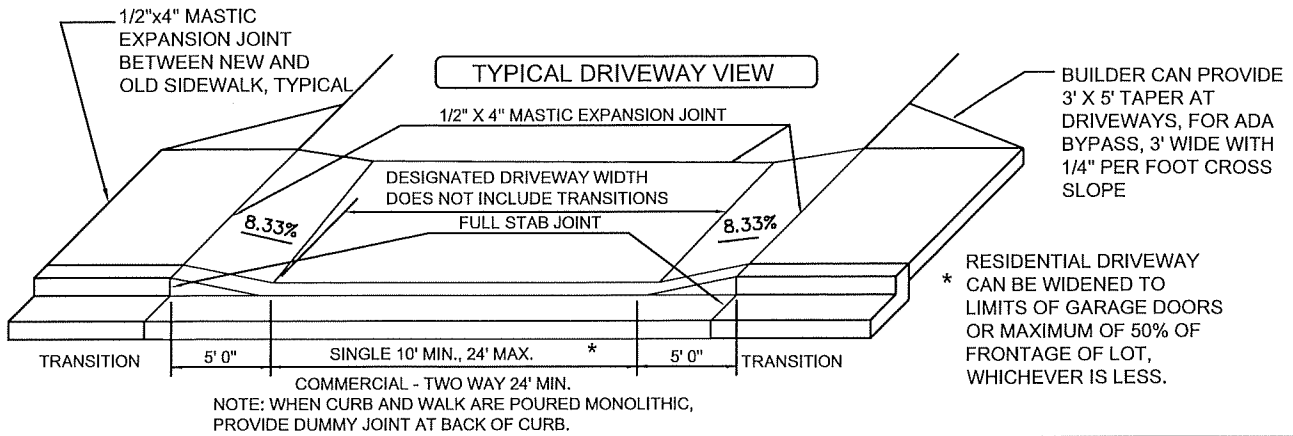

1. SIDEWALK DUMMY JOINTS ON 5' CENTERS.
2. 1/2" MASTIC EXPANSION JOINTS EVERY 30' AND AT POINTS OF CURVATURE ON CURB RETURNS.
3. 5 SACK CONCRETE
4. WIDEN SIDEWALK TO MINIMUM 6' WHEN ADJOINING A WALL, OR FENCE.

NOTE:

ONLY THE LATEST DETAIL, AS APPROVED BY THE DIRECTOR OF PUBLIC WORKS, SHALL BE USED.

ORIG.	3/17	-
REV.	DATE	DESCRIPTION

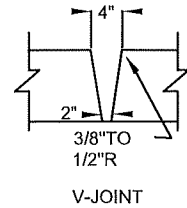
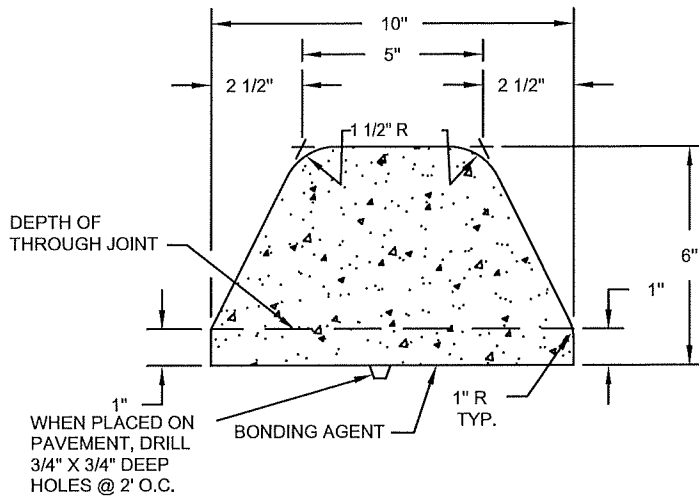

WHEN REQUIRED TO PASS DRAINAGE, CONSTRUCT 2"-V" JOINT AT 20' INTERVALS.

EXTRUDED CEMENT CONCRETE CURB

SEE STANDARDS SECTION 2-23

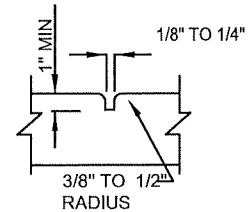
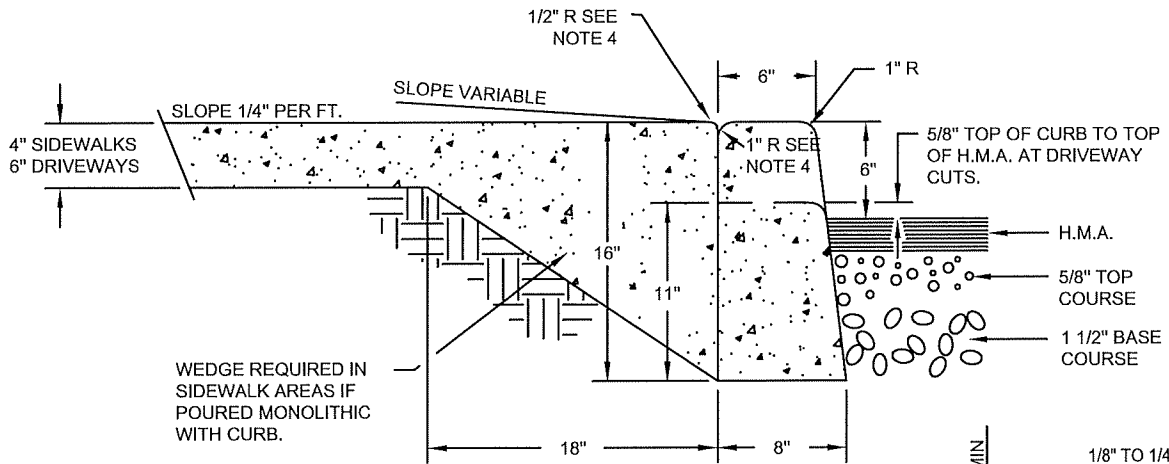

CONTRACTION JOINT

TYPE E-1 CEMENT CONCRETE CURB

SEE DWG. 2-10 FOR DETAILS NOT SHOWN.

NOTE:

1. CONCRETE SHALL BE CEMENT CONCRETE 5 SACK, SEE DRAWING 2-13.
2. CONTRACTION JOINT SHALL BE 10'-0" C/C. ALSO SEE NOTE 5.
3. EXPANSION MATERIAL (1/2" MASTIC) SHALL BE PLACED AT ALL CURB RETURNS.
4. WHEN SIDEWALK IS REQUIRED, POUR MONOLITHIC WITH SCRIBED JOINT AT BACK OF CURB.
5. WHEN EXTRUDED CURB REQUIRES PASS THROUGH DRAINAGE, CONSTRUCT A "V" JOINT AT 20' INTERVALS.

NOTE:

ONLY THE LATEST DETAIL, AS APPROVED BY THE DIRECTOR OF PUBLIC WORKS, SHALL BE USED.

ORIG.	DATE	DESCRIPTION
3/17		
REV.	DATE	DESCRIPTION

CITY OF GRANGER—STD. DETAIL

ALTERNATE CURBING DETAILS

DWG #

S9

REFER TO THE FOLLOWING LATEST WSDOT STANDARD PLANS:

- F-40.12-01 (PARALLEL CURB RAMPS)
- F-40.14-01 (COMBINATION CURB RAMPS)
- F-40.15-01 (PERPENDICULAR CURB RAMPS)
- F-40.16-01 (SINGLE DIRECTION CURB RAMPS)

NOTE:

ONLY THE LATEST DETAIL, AS APPROVED BY THE DIRECTOR OF PUBLIC WORKS, SHALL BE USED.

ORIG.	3/17	-
REV.	DATE	DESCRIPTION

CITY OF GRANGER-STD. DETAIL

PEDESTRIAN RAMPS

DWG #

S10

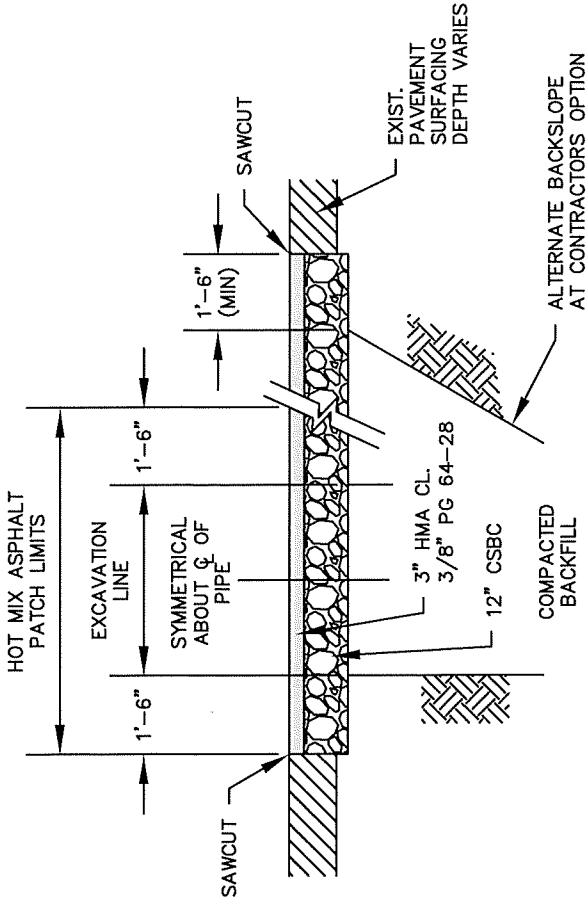

ASPHALT PAVEMENT SURFACING

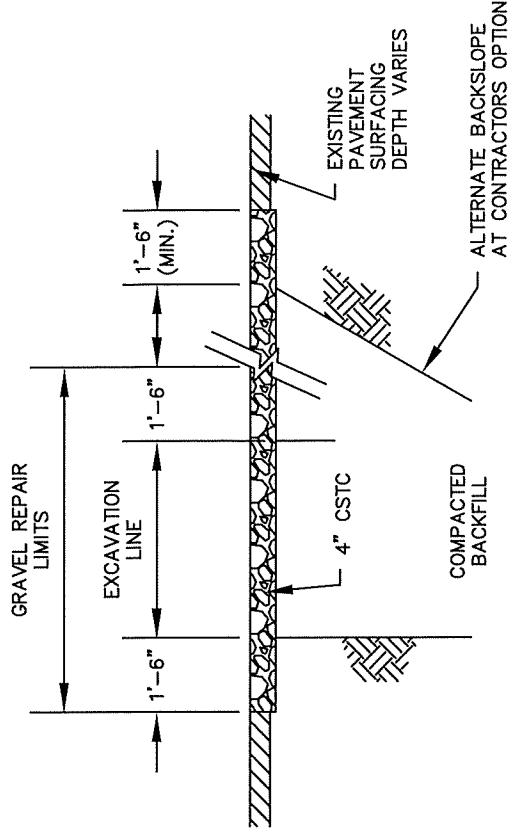

GRAVEL SURFACING

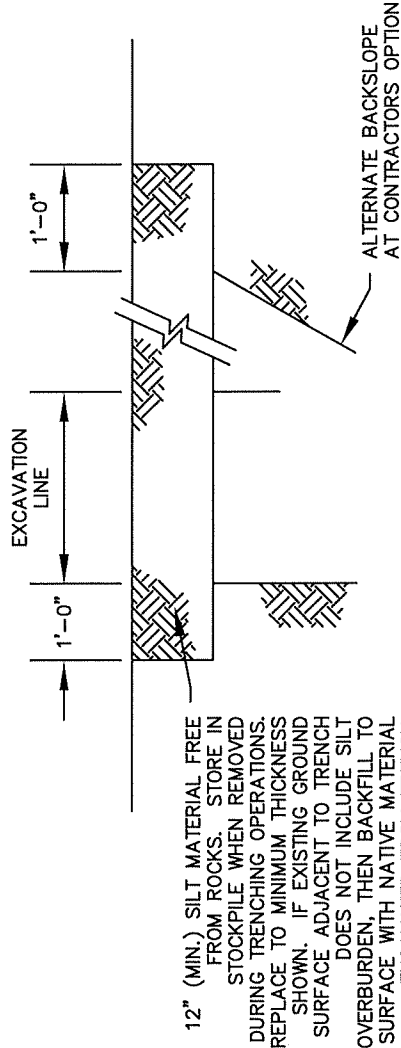

UNSURFACED AREAS

NOTE: 12" (MIN.) SILT MATERIAL FREE FROM ROCKS. STORE IN STOCKPILE WHEN REMOVED DURING TRENCHING OPERATIONS. REPLACE TO MINIMUM THICKNESS SHOWN. IF EXISTING GROUND SURFACE ADJACENT TO TRENCH DOES NOT INCLUDE SILT OVERBURDEN, THEN BACKFILL TO SURFACE WITH NATIVE MATERIAL EXCAVATED FROM TRENCH.

NOTE:

ONLY THE LATEST DETAIL, AS APPROVED BY THE DIRECTOR OF PUBLIC WORKS, SHALL BE USED.

- NOTES:
- CONTRACTOR SHALL BE RESPONSIBLE FOR ALL TRENCH SURFACE RESTORATION BEYOND THE PAYMENT LIMITS SHOWN, INCLUDING WIDER TRENCH SECTIONS RESULTING FROM LAYING BACK TRANCH SIDES AT THE CONTRACTORS OPTION. NO MEASUREMENT OR PAYMENT WILL BE MADE FOR SURFACE REPAIR BEYOND THE PAYMENT LIMITS.
 - NO MEASUREMENT OR PAYMENT WILL BE MADE OF FOR TRENCH SURFACING REPAIR IN UNSURFACED AREAS.
 - HMA PATCHING WILL BE COMPLETED WITHIN THREE DAYS.
 - ALL THICKNESS ARE COMPACTED DEPTH.

REV.	DATE	DESCRIPTION
ORIG.	3/17	-

DWG #

S11

TRENCH SURFACING REPAIR

CITY OF GRANGER--STD. DETAIL

CLASSIFICATION AND USE

THE CLASS OF CONCRETE REFERS TO THE NOMINAL NUMBER OF SACKS OF CEMENT PER CUBIC YARD, ALTHOUGH THIS DESIGNATION DOES NOT CONSTITUTE A GUARENTEE OF YIELD.

H.E.S. INDICATES HIGH EARLY-STRENGTH CEMENT AND MAY BE REQUIRED AT THE OPTION OF THE ENGINEER FOR ANY OF THE CLASSES OF MIX. WHENEVER IT IS CALLED FOR, IT WILL BE MEASURED AND PAYEMENT WILL BE MADE AS PROVIDED.

THE CONTRACTOR MAY, WITH APPROVAL OF THE ENGINEER, ELECT TO USE HIGH EARLY-STRENGTH CEMENT IN ANY OF THE MIXES, BUT NO EXTRA COMPENSATION WILL BE MADE FOR THE HIGH EARLY-STRENGTH CEMENT.

MINIMUM 28-DAY COMPRESSIVE STRENGTH SHALL BE 3,000 P.S.I. AIR-ENTRAINMENT ADMIXTURE SHALL NOT BE LESS THAN 4% OR MORE THAN 6% BY VOLUME.

HOT OR COLD WEATHER, PROTECTION WILL BE REQUIRED FOR A MINIMUM OF 7 DAYS PER THE REQUIREMENTS OF SWSS 5-05.3(13), 5-05.3(14) AND 6-02.3(6)A.

CLASS OF CONCRETE	3	4	5	5.5	6	6.5
SACKS PER CUBIC YARD	3	4	5	5.5	6	6.5

NOTE:

ONLY THE LATEST DETAIL, AS APPROVED BY THE DIRECTOR OF PUBLIC WORKS, SHALL BE USED.

ORIG.	3/17	-
REV.	DATE	DESCRIPTION

CITY OF GRANGER-STD. DETAIL

COMMERCIAL CONCRETE MIXES

DWG #

S12

NOTES:

1. FOR SKEWED CROSSWALKS, POSITION THE LINES PARALLEL TO THE TRAFFIC LANES.
2. INSTALL ADDITIONAL LINE IN SHOULDER AREA WHEN SPACING OF EDGE OF LANE LINE BLOCK TO FACE OF CURB WOULD EXCEED 5'.
3. 6 FOOT FOR ALL STREETS & 10 FOOT FOR SCHOOL CROSSINGS.
4. STOP BAR SIZE 18".

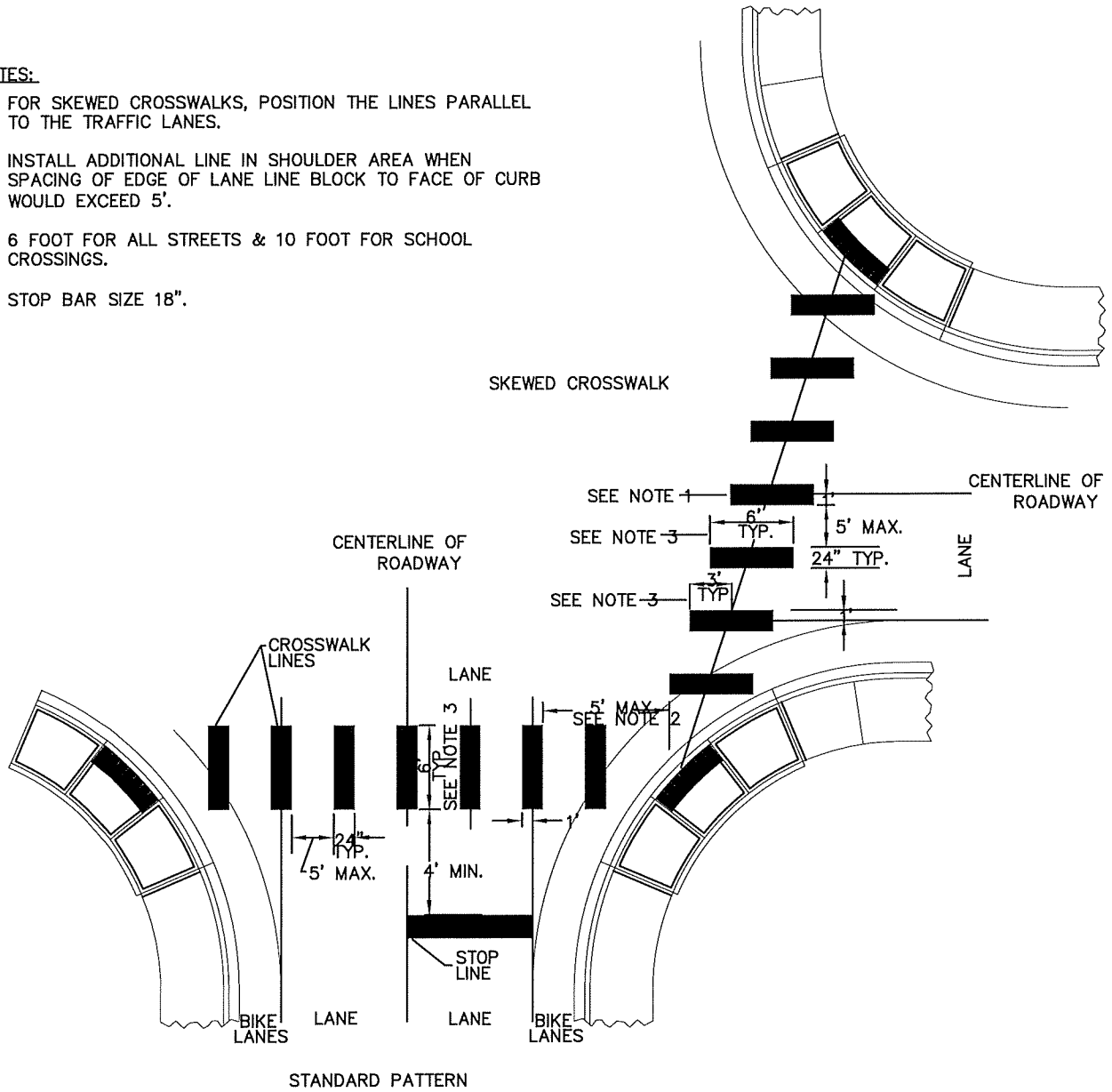

NOTE:

ONLY THE LATEST DETAIL, AS APPROVED BY THE DIRECTOR OF PUBLIC WORKS, SHALL BE USED.

ORIG.	3/17	-
REV.	DATE	DESCRIPTION

CITY OF GRANGER—STD. DETAIL

CROSSWALK STRIPING DETAIL

DWG #

S13

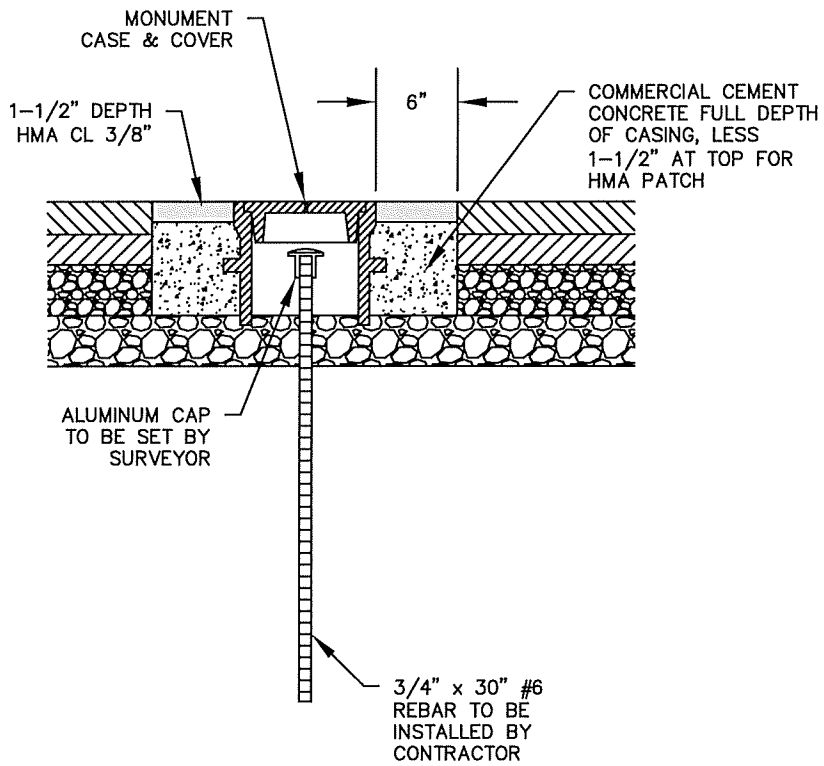

NOTES:

1. TOP OF MONUMENT CAP SHALL BE 3" BELOW FINISH GRADE.
2. MONUMENT, MONUMENT CASE & COVER TO BE PLACED AFTER FINAL LIFT OF HMA.
3. MONUMENT CASE, COVER AND RISERS SHALL MEET REQUIREMENTS OF SECTION 9-22 AS MANUFACTURED BY OLYMPIC FOUNDRY OR EQUAL.

NOTE:

ONLY THE LATEST DETAIL, AS APPROVED BY THE DIRECTOR OF PUBLIC WORKS, SHALL BE USED.

ORIG.	3/17	-
REV.	DATE	DESCRIPTION

CITY OF GRANGER—STD. DETAIL

SURVEY MONUMENT

DWG #

S14

CHAPTER 8 - IRRIGATION SYSTEM IMPROVEMENTS

GENERAL REQUIREMENTS FOR IRRIGATION SYSTEM IMPROVEMENTS

All extensions and additions to the City of Granger's irrigation water system shall conform to the Design and Construction Standards of the City of Granger

All new lots and developments shall be served by a public irrigation water supply line to be maintained by the City of Granger and located adjacent to the lot or development site. The irrigation water supply line shall be capable of providing sufficient flow and pressure to satisfy service requirements of the proposed lots and development requirements. The irrigation water supply lines shall be sized by a professional engineer, licensed in the state of Washington, to provide sufficient flow and pressure to the development.

Irrigation water lines shall be extended by the Developer to the point where the adjoining property owner's responsibility for further extension begins. This typically requires an extension across the entire frontage of the property to the property line of the adjoining owner. In some cases, it will require dedication of an easement and a line extension across the property or extension across two or more sides of the developing property.

Irrigation water line oversizing, above that required for the particular development being submitted, may be required by the City of Granger to be installed for future extension. The cost of the materials only for the oversizing shall be reimbursed to the Developer by the City. The Developer shall submit actual material invoices showing the actual cost of the materials furnished and the cost of the same materials of the size required for the development.

Cover over new irrigation water lines shall be a minimum of 24" and a maximum of 48".

All irrigation water lines shall be looped, where possible. Temporary dead-end mains over 300 feet in length will only be allowed where future irrigation water line looping will be assured.

Maximum valve spacing for irrigation water lines will be 800 linear feet. Valves will be furnished and installed on two legs of new irrigation water tees and three legs of new irrigation water crosses and where deemed necessary by the City Public Works Director.

All live taps of irrigation water lines shall be performed by the City (or City's representative with Public Works Director's approval) using a cut-in tee with gate valve and transition couplings paid for by the Developer.

Air and vacuum release valves shall be furnished and installed at high points in the system. System drains shall be furnished and installed at all low points in the system.

Domestic water and non-potable irrigation water lines shall be separated in accordance with Section C 1-9.1 of the *Criteria for Sewage Works Design, August 2008*, by the Washington State Department of Ecology.

The design of irrigation water lines and appurtenances is subject to review and approval by the City of Granger Public Works Director. The Public Works Director may, at his discretion, adjust these Design and Construction Standards as necessary to facilitate installation of irrigation water lines and appurtenances for the health, safety, and protection of the general public.

SPECIAL PROVISIONS FOR WATER SYSTEMS

The following sections of the WSDOT Standard Specifications have been amended or supplemented as described below and apply to the construction of public works irrigation water system improvements within the City of Granger.

7-09 WATER MAINS

7 -09.2 Materials

Pipe for main line approved for use shall be as follows:

Pipe for Main Line:

Polyvinyl Chloride (PVC) Pressure Pipe
Galvanized Iron Pipe

Supplement this section with the following:

Polyvinyl Chloride (PVC) Pressure Pipe: PVC pipe shall conform to the requirements of Section 9-30.1 (5)A.

Fittings for Main Lines:

Connection Couplings: Couplings for Galvanized Iron or PVC pipe, either transition or straight couplings, shall be compression type flexible couplings conforming to Section 9-30.2(7) of the Standard Specifications.

Aggregates:

Gravel Backfill for Pipe Zone: Imported pipe zone material for flexible pipes shall be crushed Surfacing Top Course meeting the requirements of section 9-03.9(3), and shall be placed and compacted in layers as designated by the City. Pipe zone material for rigid pipes shall be Crushed Surfacing Base Course meeting the requirements of Section 9-03.9(3).

Trench Backfill: All longitudinal water main trenches (parallel to curb) shall be backfilled full depth above the pipe zone with native material (free of organic material, wood, rocks, or pavement chunks larger than 6-inches in maximum dimension), unless otherwise directed by the City of Granger. Street crossing trenches and other locations as directed by the City of Granger shall be backfilled full depth with imported select backfill. Imported select backfill shall be crushed surfacing base course, placed and compacted in layers.

7 -09.3 Construction Requirements

7-09.3(5) Grade and Alignment

Replace the first sentence of the third paragraph with the following:

The depth of trenching for irrigation water mains shall be such to provide a minimum cover of 2 feet and a maximum cover of 4feet, unless otherwise approved by the Public Works Director.

7-09.3(9) Bedding the Pipe

Supplement this section with the following:

All construction work shall be inspected by the City or its representative before pipe installation and backfilling. Imported pipe zone bedding/backfill for pipes shall be in accordance with Section 7-09.2 above, placed and compacted per the Standard Specifications. Bedding shall be placed under all pipe.

7-09.3(10) Backfilling Trenches

Supplement this section with the following:

Street crossing trenches, and other locations as directed, shall have the trench backfilled full depth with Imported Select Backfill. The Public Works Director may require the use of Controlled Density Fill (CDF) for trench backfill in certain circumstances. The requirements for CDF are set forth in CHAPTER 7, Section 8-30 of these Special Provisions.

7-09.3(11) Compaction of Backfill

Delete the first paragraph and supplement this section with the following:

Mechanical compaction shall be required for all trenches. The Contractor is hereby cautioned that time extensions shall not be granted due to unstable trench backfill conditions caused by excessive watering. The Contractor shall be responsible for correcting such conditions caused by his own construction activities.

The density of the compacted material shall be at least 95% of the maximum density as determined by ASTM D 1557 Tests (Modified Proctor). The Contractor shall notify the City 24 hours in advance of when they are ready for in-place density tests of the trench line. The Contractor/Developer shall be responsible for scheduling and paying for all compaction testing required. Refer to section 1-05.6(1) of these Design and Construction Standards. Density tests shall be taken at various depths in the trench. The Contractor shall provide a backhoe and operator for the excavation and backfill of test holes. Placement of courses of aggregate shall not proceed until density requirements have been met.

The first 500 feet of trench backfill operations shall be considered a test section for the Contractor to demonstrate his backfilling and compaction techniques. The Contractor shall notify the City at least 3 working days prior to beginning trench excavation and

backfill operations and the Contractor will arrange for in-place density tests to be taken on the completed test section in accordance with the above requirements. No further trenching will be allowed until the specified density is achieved in the test section. Passing in-place density tests in the test section will not relieve the Contractor from achieving the specified densities throughout the project.

7-09.3(12)A Locating Wire (New Section)

The following new section shall be added to the Standard Specifications:

A continuous solid copper locating wire shall be placed along the top of all water pipe. This wire shall be secured to the top of the pipe at maximum 10-foot intervals using 6-inch strips of 2-inch wide duct tape. All splices shall be tied, electrically continuous, and made waterproof. Access to terminal ends of the locating wire shall be made at locating wire boxes, per the details shown on the Drawings. The result of this installation shall be a continuous wire circuit electrically isolated from ground. The Contractor shall be responsible for testing continuity and for testing isolation from ground in the wire after all work has been completed on the test section. The Contractor is advised to do intermediate testing on his own after backfilling operations and prior to surface restoration work to be sure continuity is maintained. If there is a break or defect in the wire, it shall be the Contractor's responsibility to locate and repair the defect. The continuity of the location wire shall be tested from one test load point to the next by use of a temporary wire laid between test points in-line with an ohmmeter. Resistance shall be measured with an approved ohmmeter that has been properly calibrated. The continuity of a test section will be accepted if the resistance of the test section does not exceed 5 ohms per 500 feet of location wire being tested. Isolation from ground shall be measured with a megohmmeter and shall be a minimum of 20 megohms for any section of location wire tested. The City shall witness the acceptance test.

7-09.3(19)A Connections to Existing Mains

Supplement this section with the following:

New irrigation water lines shall be tested and flushed prior to making connection to existing main and being placed into operation.

No existing line valves shall be closed without permission by the City of Granger.

7-12 VALVES FOR WATER MAINS

7 -12.2 Materials

Supplement this section with the following:

Gate Valves: All valves sizes 1-inch through 8-inch shall be gate valves manufactured in the U.S. and shall conform to the latest revision of AWWA Resilient Seated Gate Valves Standard C509 and AWWA C104.

Ball Valves: All valves smaller than 1-inch shall be ¼ turn ball valves, made of either brass or stainless steel.

All gate valves shall have non-rising stems and open counterclockwise. Gate valves 4-inch and larger shall have flanged and/or mechanical joint connections, as shown on the Plans. Stuffing box shall be O-ring type, and shall be provided with a 2-inch square AWWA operating nut

Valve Boxes shall be 6" plastic round box with overlapping ICV cover. Extensions to the valve boxes shall be 6" PVC schedule 40 pipe, field cut to length and centered over the valve.

7 -12.3 Construction Requirements

Supplement this section with the following:

Valves: Upon completion of all work in connection with this Contract, the Developer/Contractor shall contact the City of Granger Public Works for opening irrigation water valves. Valves shall only be operated by City Public Works staff.

Valve Boxes: Valve boxes should be set to position during backfilling operations so they will be in a vertically centered alignment to the valve operating stem. The top of the box will be at final grade.

The Contractor shall adjust all irrigation water valve boxes to the final grade of the surrounding area including new concrete sidewalk, asphalt paving, gravel surfacing, or topsoil surfacing, in accordance with the details shown on the Drawings.

The Contractor shall keep the valve boxes free from debris caused by the construction activities. All valve boxes will be inspected during final walk-thru to verify that the valve box is plumb and that the valve wrench can be placed on the operating nut.

7-15 SERVICE CONNECTIONS

7-15.1 Description

Replace this section with the following:

This work consists of the installation of new cut-in tee, valve and service pipe as shown on the Plans.

7 -15.2 Materials

Supplement this section with the following:

Service Pipe: New service pipe shall be PVC schedule 40, class 200 or better, galvanized iron or approved equal as shown on the Plans.

Pipe Bedding and Backfill: Pipe bedding and select backfill shall be utilized for trench backfill as directed by the City in accordance with Section 7-09.2 of the Special Provisions.

ROUND VALVE BOX WITH
GREEN LID MARKED
"IRRIGATION CONTROL VALVE"

24" MIN.
48" MAX.

1" SERVICE PIPE
CL. 200,
SCHEDULE 40
OR BETTER

WELL DRAINING MATERIAL

1" I.P.S.
THREAD X SLIP
COUPLER

1" CL. 150, IPS,
BRASS GATE VALVE

NOTE:

ONLY THE LATEST DETAIL, AS APPROVED BY THE
DIRECTOR OF PUBLIC WORKS, SHALL BE USED.

ORIG.	9/17	-
REV.	DATE	DESCRIPTION

CITY OF GRANGER—STD. DETAIL

IRRIGATION WATER SERVICE

DWG #

I 1

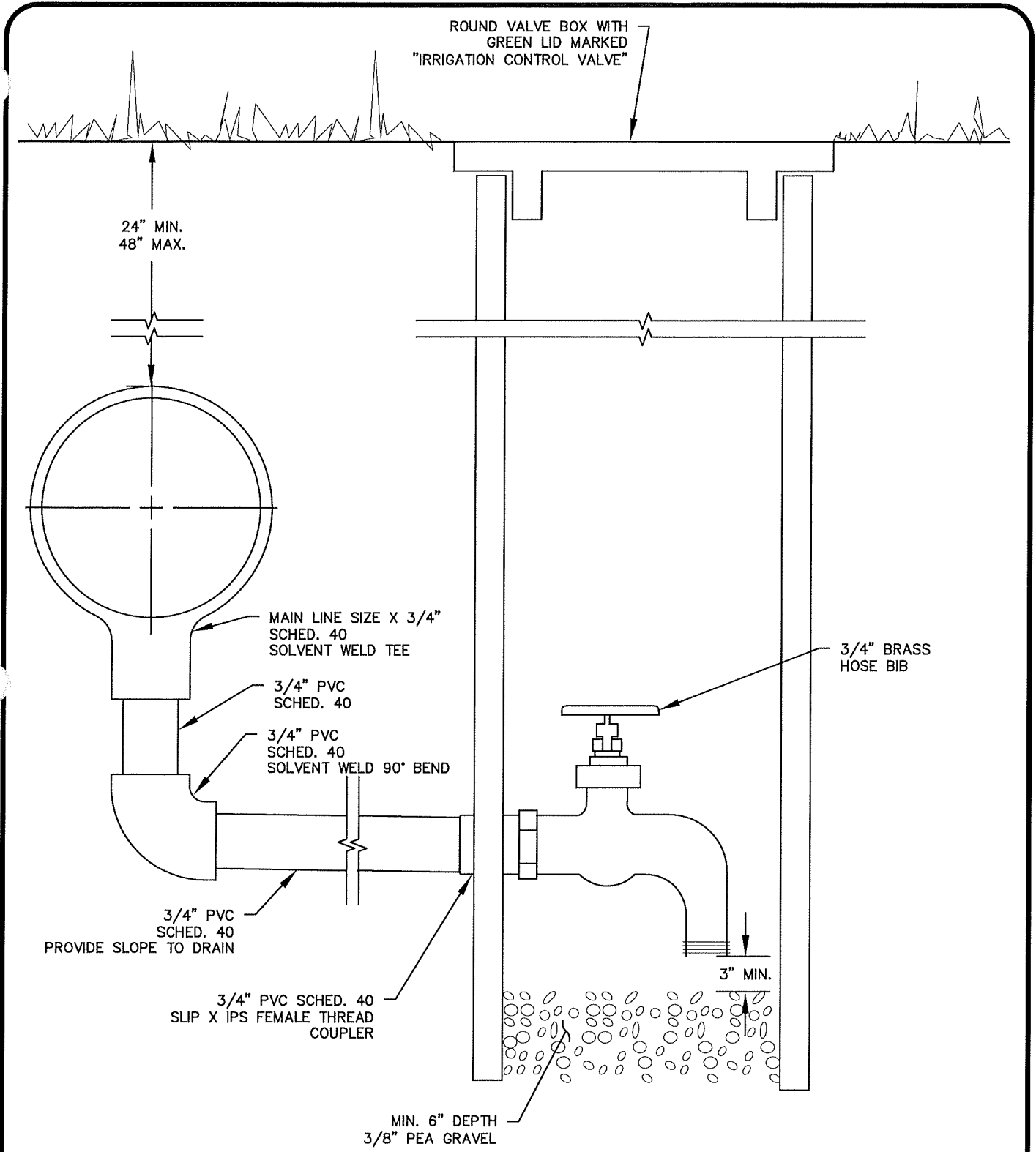

ROUND VALVE BOX WITH GREEN LID MARKED "IRRIGATION CONTROL VALVE"

24" MIN.
48" MAX.

MAIN LINE SIZE X 3/4" SCHED. 40 SOLVENT WELD TEE

3/4" PVC SCHED. 40

3/4" PVC SCHED. 40 SOLVENT WELD 90° BEND

3/4" PVC SCHED. 40 PROVIDE SLOPE TO DRAIN

3/4" PVC SCHED. 40 SLIP X IPS FEMALE THREAD COUPLER

3/4" BRASS HOSE BIB

3" MIN.

MIN. 6" DEPTH 3/8" PEA GRAVEL

NOTE:

ONLY THE LATEST DETAIL, AS APPROVED BY THE DIRECTOR OF PUBLIC WORKS, SHALL BE USED.

ORIG.	9/17	-
REV.	DATE	DESCRIPTION